

# Technical Review

To Advance Techniques in Acoustical, Electrical, and Mechanical Measurement

## Artificial Ears

Part 2

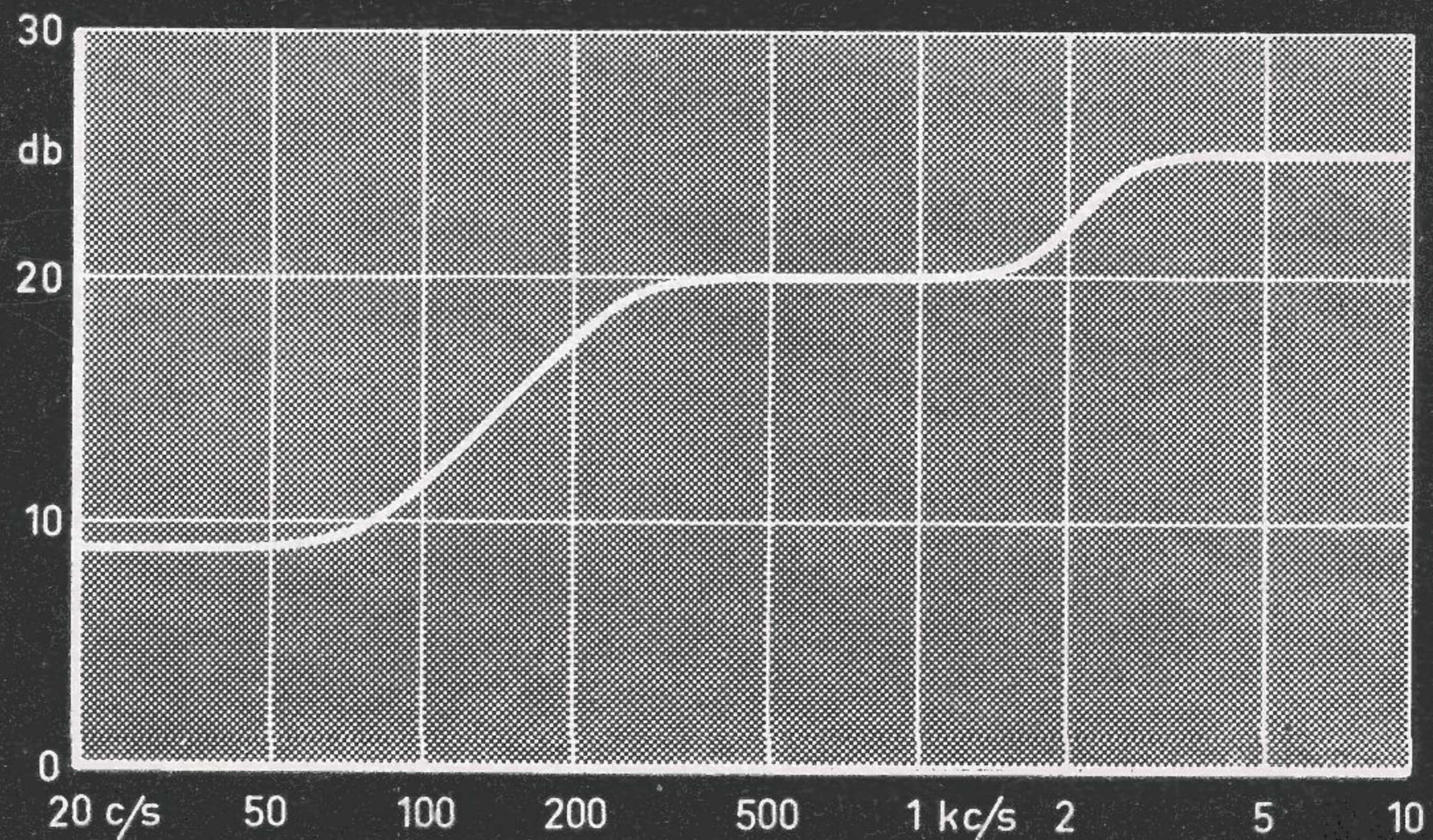
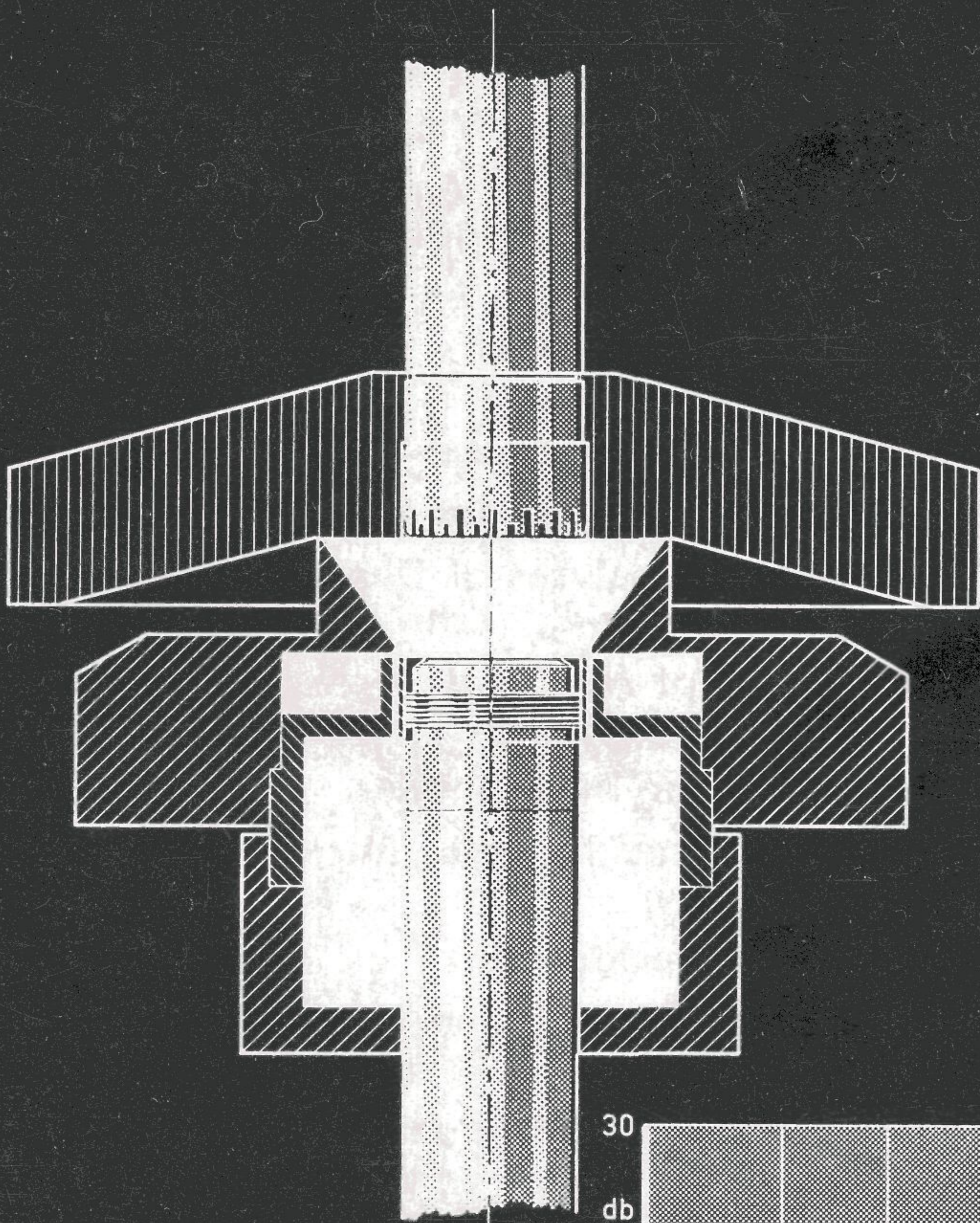

**PREVIOUSLY ISSUED NUMBERS OF  
BRÜEL & KJÆR TECHNICAL REVIEW**

- 1-1956 Noise Measurements and Analyses.
- 2-1956 Use of Resistance Strain Gauges to determine Friction Coefficients.
- 3-1956 Determination of Acoustical Quality of Rooms from Reverberation Curves.
- 4-1956 Electrical Measurements of Mechanical Vibrations.
- 1-1957 Strain Gauge Measurements.
- 2-1957 Sound Analysis in Industrial Processes and Production.
- 3-1957 Measurement on Tape Recorders.
- 4-1957 Measurements of Modulus of Elasticity and Loss Factor for Solid Materials.  
Surface Roughness Measurements.
- 1-1958 Measurement of the Complex Modulus of Elasticity.
- 2-1958 Vibration Testing of Components.  
Automatic Level Regulation of Vibration Exciters.
- 3-1958 Design Features in Microphone Amplifier Type 2603 and A. F. Spectrometer Type 2110.  
A true RMS Instrument.
- 4-1958 Microphonics in Vacuum Tubes.
- 1-1959 A New Condenser Microphone.  
Free Field Response of Condenser Microphones.
- 2-1959 Free Field Response of Condenser Microphones (Part II).
- 3-1959 Frequency-Amplitude Analyses of Dynamic Strain and its Use in Modern Measuring Technique.
- 4-1959 Automatic Recording of Amplitude Density Curves.
- 1-1960 Pressure Equalization of Condenser Microphones and Performance at Varying Altitudes.
- 2-1960 Aerodynamically Induced Noise of Microphones and Windscreens.
- 3-1960 Vibration Exciter Characteristics.
- 4-1960 R.M.S. Recording of Narrow Band Noise with the Level Recorder Type 2305.
- 1-1961 Effective Averaging Time of the Level Recorder Type 2305.
- 2-1961 The Application and Generation of Audio Frequency Random Noise.
- 3-1961 On the Standardisation of Surface Roughness.
- 4-1961 Artificial Ears.

# TECHNICAL REVIEW

No. 1 — 1962

# Artificial Ears for the Calibration of Earphones of the External Type

by

*Per V. Brüel, Erling Frederiksen*

and

*Gunnar Rasmussen.*

**Continued from "Technical Review" 4-1961.**

## **ABSTRACT**

In connection with the development of an artificial ear for audiometer use made for Working Group No. 11 under TC 29 at the International Electrotechnical Commission, some physical properties and limitations of such were discussed in "Technical Review" 4-1961. The construction of a standard high impedance earphone (electrostatic type) with a flat frequency response curve over a large frequency range was also described. A suggestion for an artificial ear which should be suitable as an international standard is given in this issue of the "Technical Review" as a conclusion of the work. This artificial ear can be used over a large frequency range, gives highly consistent results, and is easy to make.

## **SOMMAIRE**

Un prototype d'oreille artificielle étalon synthétisant les résultats des recherches entreprises sous l'égide de la CEI (TC 29, groupe 11) et décrites dans le précédent numéro de la «Technical Review» (no. 4-1961) est présenté dans cette seconde et dernière partie de l'article. Non seulement le volume mais aussi la forme des cavités de l'oreille artificielle ont été déterminés de façon à obtenir une réponse correcte dans toute la gamme acoustique. La construction est entièrement réalisée en matériaux durs amagnétiques. Pour déterminer avec quelle précision il est possible de reproduire pratiquement l'oreille étalon définie par ce prototype, il fut copié en trois exemplaires. Les courbes de réponse des trois copies se sont montrées identiques à  $\pm 0.5$  db près ( $\pm 1$  db aux parties de pente forte).

## **ZUSAMMENFASSUNG**

Einige physikalische Gegebenheiten und Grenzbedingungen wurden in Verbindung mit der Entwicklung eines künstlichen Ohres für Gruppe No. 11 in TC29 des »International Electrotechnical Commission« in Technical Review Nr. 4-1961 besprochen. Ein Standard-Kopfhörer mit hoher Impedanz und sehr breitem Frequenzbereich wurde auch beschrieben. Als Ergebnis der Arbeiten wird ein Vorschlag für ein künstliches Ohr in dem folgenden gegeben, das als internationaler Standard geeignet wäre. Dieses künstliche Ohr kann in einem weiten Frequenzbereich verwendet werden, gibt gut reproduzierbare Messwerte und ist leicht herzustellen.

## **Conclusions Leading to an Artificial Ear.**

It would seem reasonable to shape the artificial ear as it is done in the British Standard (ref. 3), and as proposed by P. Chavasse (ref. 10) from the French PTT and by I. Nabelik (ref. 2). They are proposing a fixed shape upon which the ear cap is placed. Furthermore, the opening very much resembles an average auricula, the outer part allowing different shapes of rubber pads to be attached, and the sensitive element of the microphone diaphragm should be placed at the entrance to the "ear channel". The opening diameter is 25 mm. The total volume may be  $4.5 \text{ cm}^3$  allowing the ear cap under test to have a slightly curved shape and still obtain around

5—6 cm<sup>3</sup> volume, while a very flat ear cap, possibly extended into the auricula would give a smaller volume similar to that obtained on the human ear. At higher frequencies we found our measurements to be very well in agreement with those leading to the design of the Swiss artificial ear and that described by Nabelik (ref. 2). Both of them have divided the coupler volume in two parts constituting the volume of the ear channel 1.2 cm<sup>3</sup> + 0.8 cm<sup>3</sup> for the equivalent volume of the ear drum being 2 cm<sup>3</sup> (ref. 2 and 5) and the outer ear as enclosed in the auricula. The two volumes are connected by a slot in the Swiss ear, and by Nabelik it is made up like the human ear by a 7 $\phi$  × 21 mm tube and a volume equal to the equivalent volume of the human ear. These arrangements are very important if the frequency response of the artificial ear should be even an approximation to that of the human ear at frequencies above 2000 c/s, a very important range for audiometric testing. We found, like the above-mentioned references, that the impedance changes rather sharply between 2000 and 3000 c/s, see also ref. 11.

At high frequencies the shape of the outer volume is very important. Above 6000 c/s it is necessary to consider the pressure distribution in the coupler. Although the active coupler volume at these frequencies is rather small, the size, shape, and the positioning of the sensitive part of the microphone diaphragm may change the response by several db. A very enlightening discussion of such problems is given in ref. 9.

The sensitivity distribution on the diaphragm of the B & K Microphones Type 4131 and 4132 have been measured previously, and the data are shown

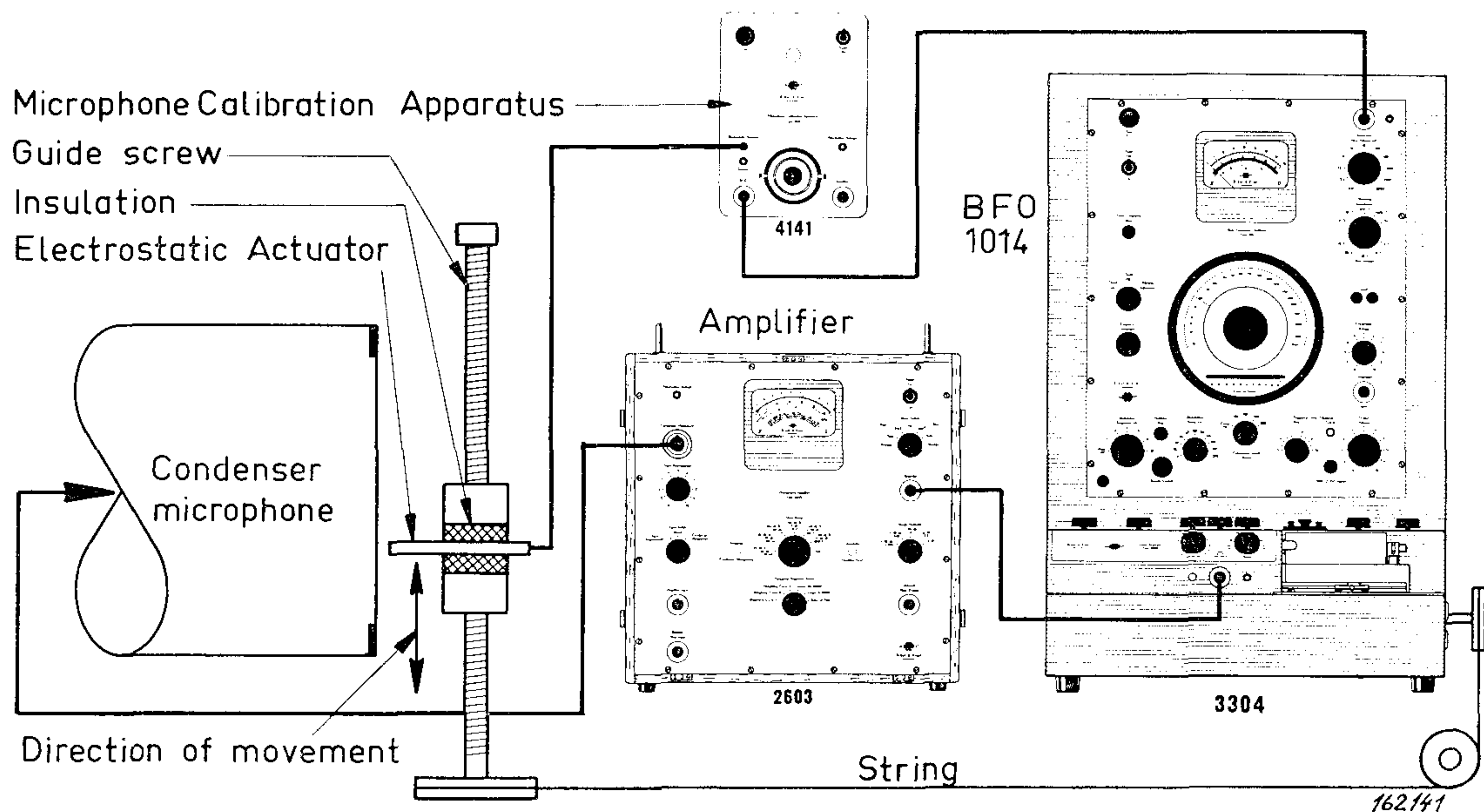
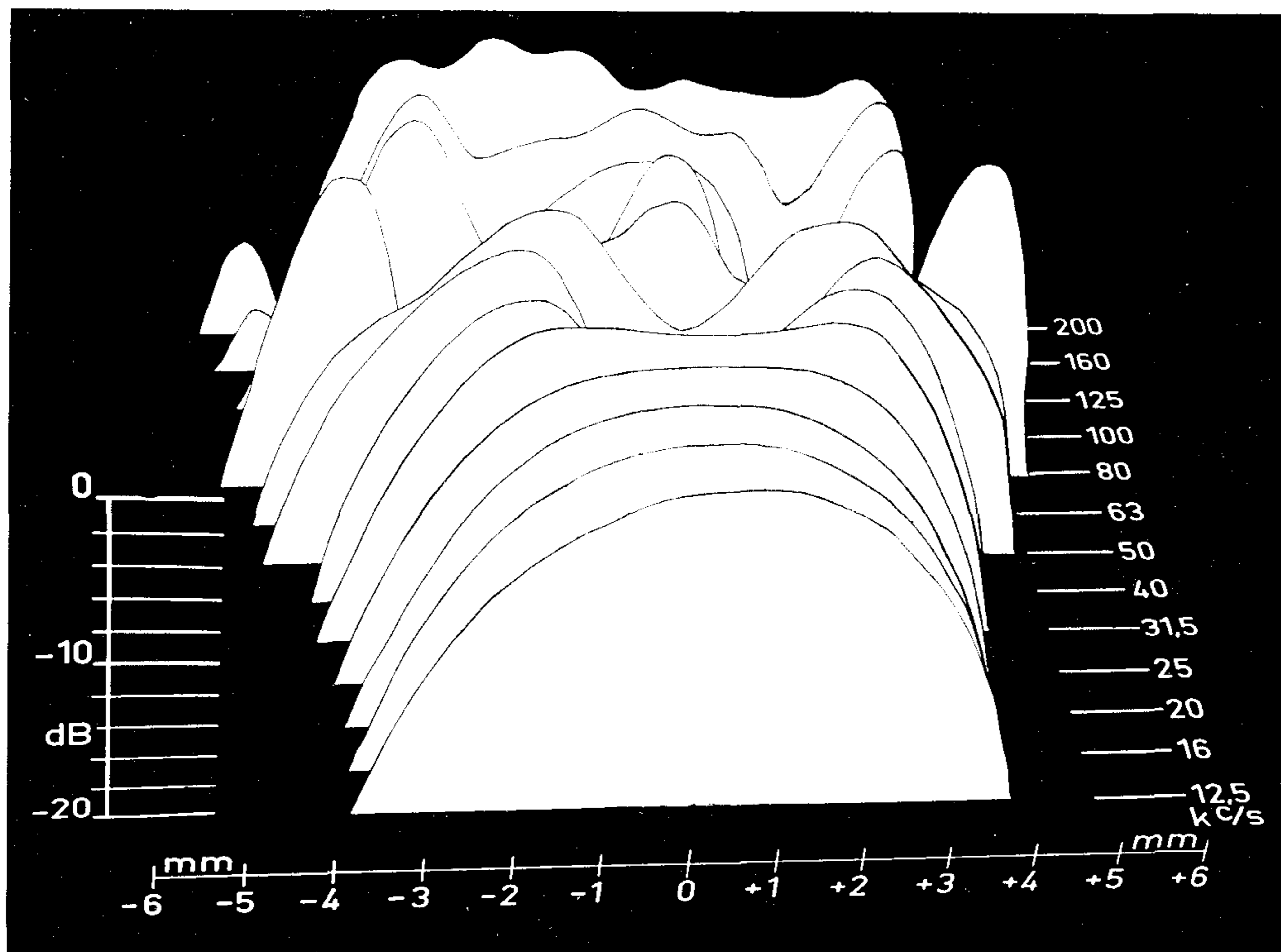

Fig. 23. Arrangement used for the measurement of the sensitivity distribution over the 1/2" microphone diaphragm.

in ref. 12. For the  $\frac{1}{2}$ " Microphone Cartridge Type 4134 the sensitivity distribution has been measured in the arrangement shown in Fig. 23, and the curves are shown in Fig. 24.

The curves show that the sensitivity distribution for the  $\frac{1}{2}$ " cartridges used for this work is very consistent up to 20 kc/s. Furthermore the same distribution is maintained for all cartridges produced of this type.



162142

Fig. 24a.  
Overall view of the sensitivity distribution of the  $\frac{1}{2}$ " condenser microphone Type 4134 used.

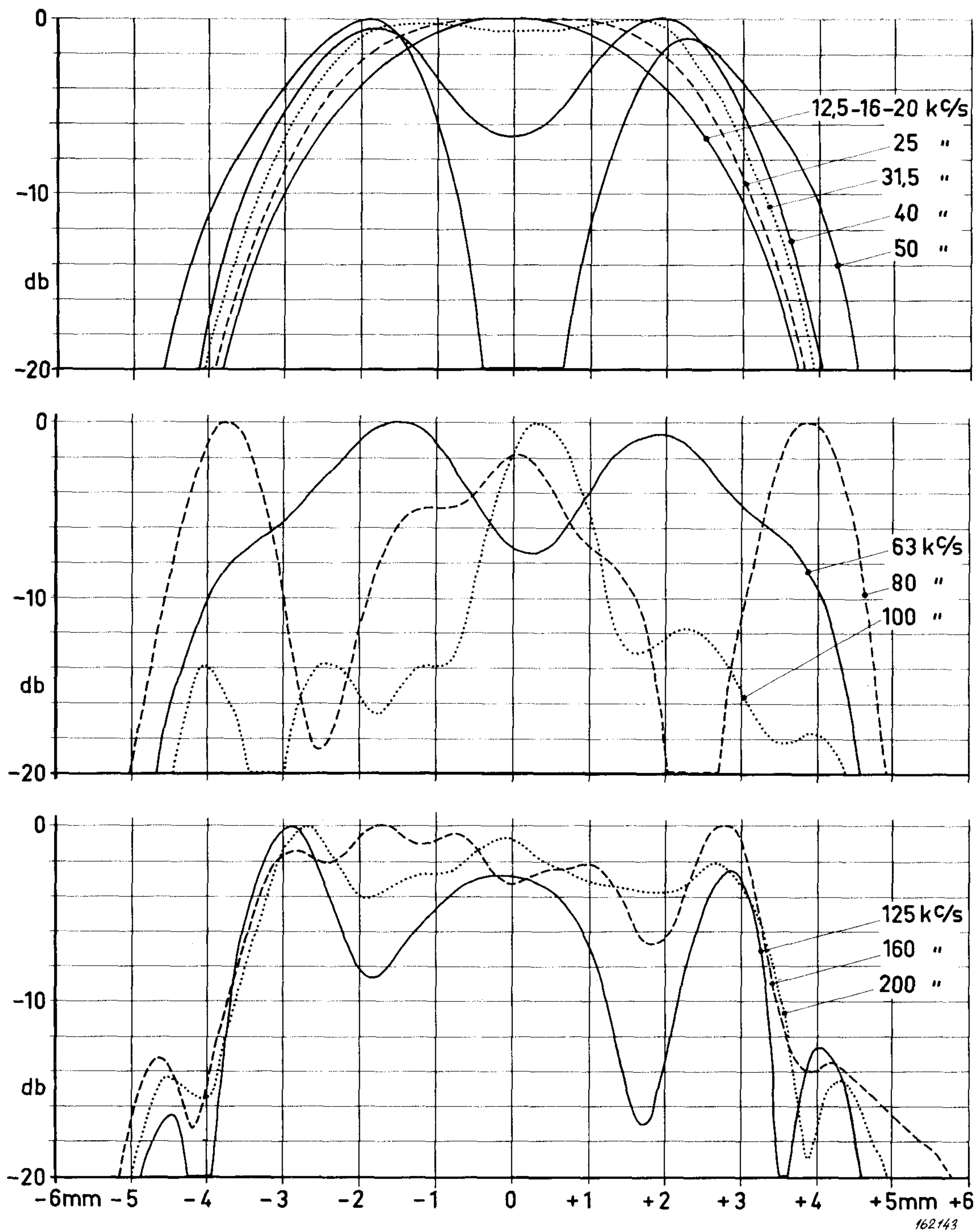

Fig. 24b.

*Sensitivity distribution curves. The curves below 20 kc/s are all alike. The diaphragm resonances occur at 25 kc/s. The graphs show the rapid change in diaphragm pattern in the 31.5 kc/s to 100 kc/s range, although the phase relationship is not indicated. Above 100 kc/s the vibration pattern is determined by the air cushion between the diaphragm and the back plate of the condenser microphone.*

Based on the above-mentioned considerations, averaging the data obtained from the different sources and trying to work all the information together into one single unit, the following proposal may be given:

The artificial ear may be built up of hard non-magnetic material, e.g. brass, by making a coupler as shown in Fig. 25.

The auricula opening is 25 mm  $\varnothing$ .

The measuring microphone is placed in the centre 8.4 mm below the opening.

The sensitive area is circular and has a diameter of 7.2 mm, like the opening of the ear channel.

The inner volume is 2 cm<sup>3</sup>, and the slot connecting the auricula with the inner volume is adjusted by screwing a fine thread.

The position of the slope is defined by the curve obtained from measure-

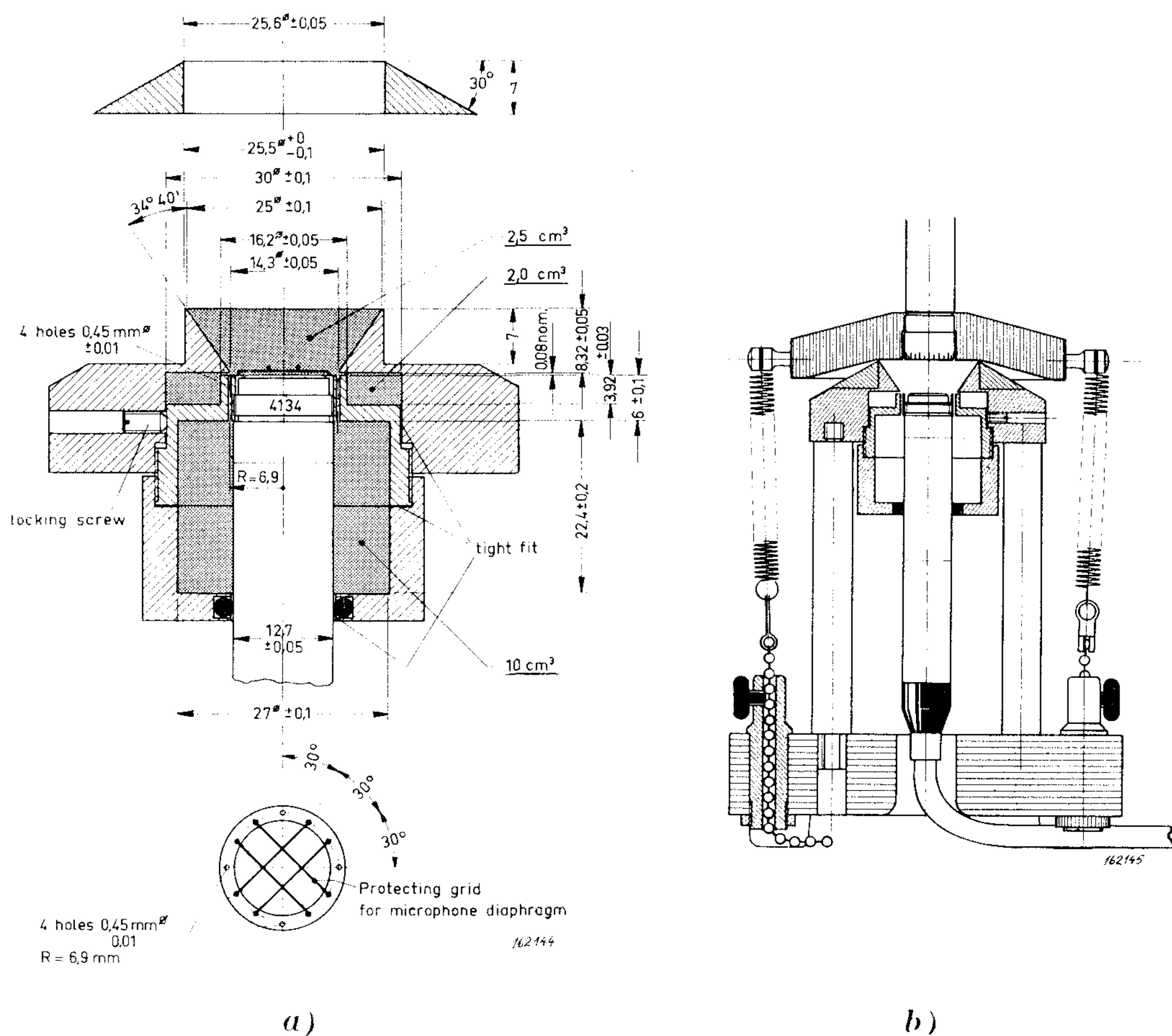

Fig. 25.

- a) Dimensions and practical arrangement for the artificial ear, which was the result of this work. The slot between the 2 cm<sup>3</sup> and the 2.5 cm<sup>3</sup> volumes is accurately adjusted by screwing the lower parts in or out relative to the upper part.
- b) Practical arrangement including the earcap used for testing the artificial ear. The yoke is also useful for holding other units to be tested on the ear.



ment with a high impedance sound source.

The positioning of the threaded part is locked by a small screw after adjustment.

The slope of the low frequency response characteristic is determined by four small holes 0.45 mm in diameter as described by I. Barducci and F. Bianchi in ref. 7.

The impedance at very low frequencies is determined by the 10 cm<sup>3</sup> coupler closing the total ear as the human ear may be by tight coupling to the ear cap. For practical work it is important to have a closed system in order to avoid the disturbing influence of the very often dominating low frequency pressure components of the external disturbances.

The steepness of the slope at 150 c/s, as measured with a high-impedance telephone receiver, does not coincide with the 6 db/octave slope that one should expect with a pure resistive leakage component. Comparing the different sources mentioned in the reference literature gives an average slope of 10 db/octave.

An artificial ear built up in this way is reasonable to manufacture and very reproduceable. A small series of 3 besides the prototype have been made, and the calibration curves after adjustment are, for comparison, shown in Fig. 26 on the same chart. The reproducibility may be expected to be within  $\pm 0.5$  db over most of the frequency range and within  $\pm 1$  db on the steep part of the slopes.

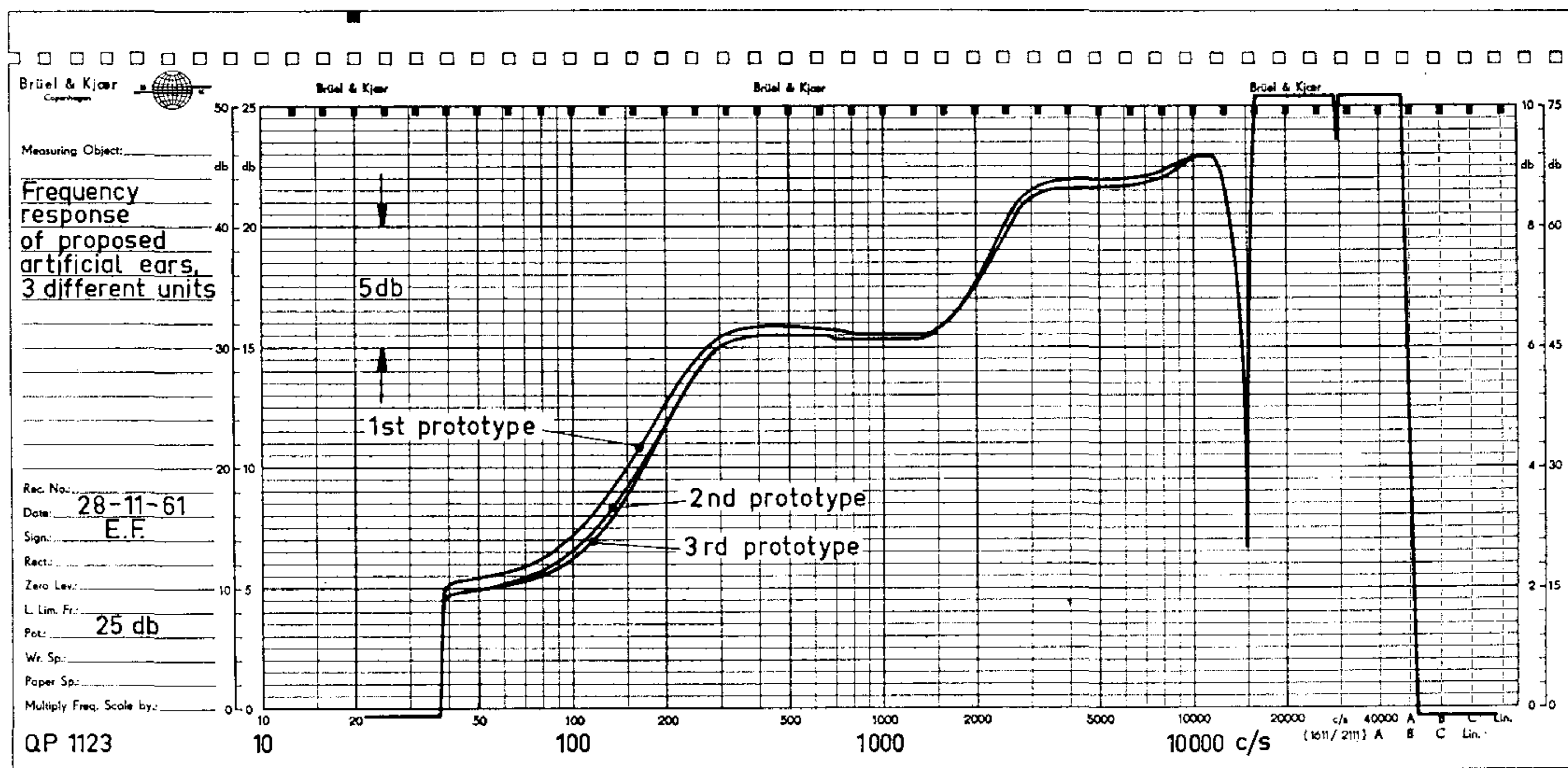

Fig. 26. Frequency response of the artificial ear as this will appear when tested by a high impedance telephone. Curves for three different units are shown. Compare against Fig. 5b, obtained on a human ear with the same high impedance telephone.

The microphone cartridges may be reciprocity calibrated, or calibrated by means of a pistonphone to within  $\pm 0.2$  db as shown in Fig. 27.

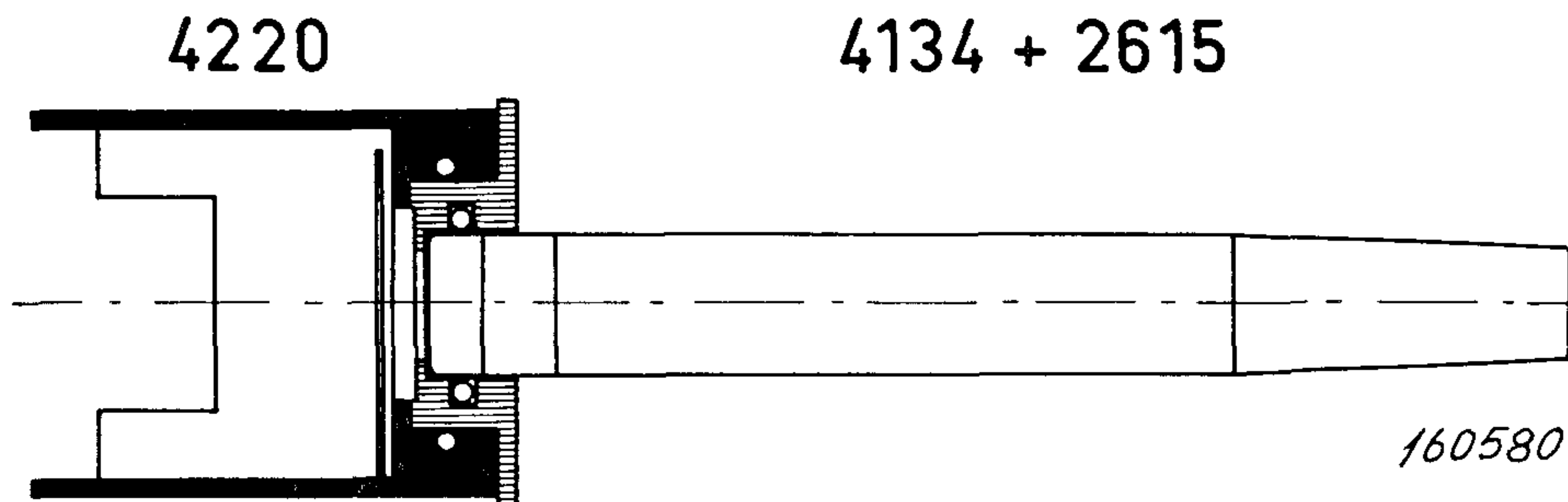
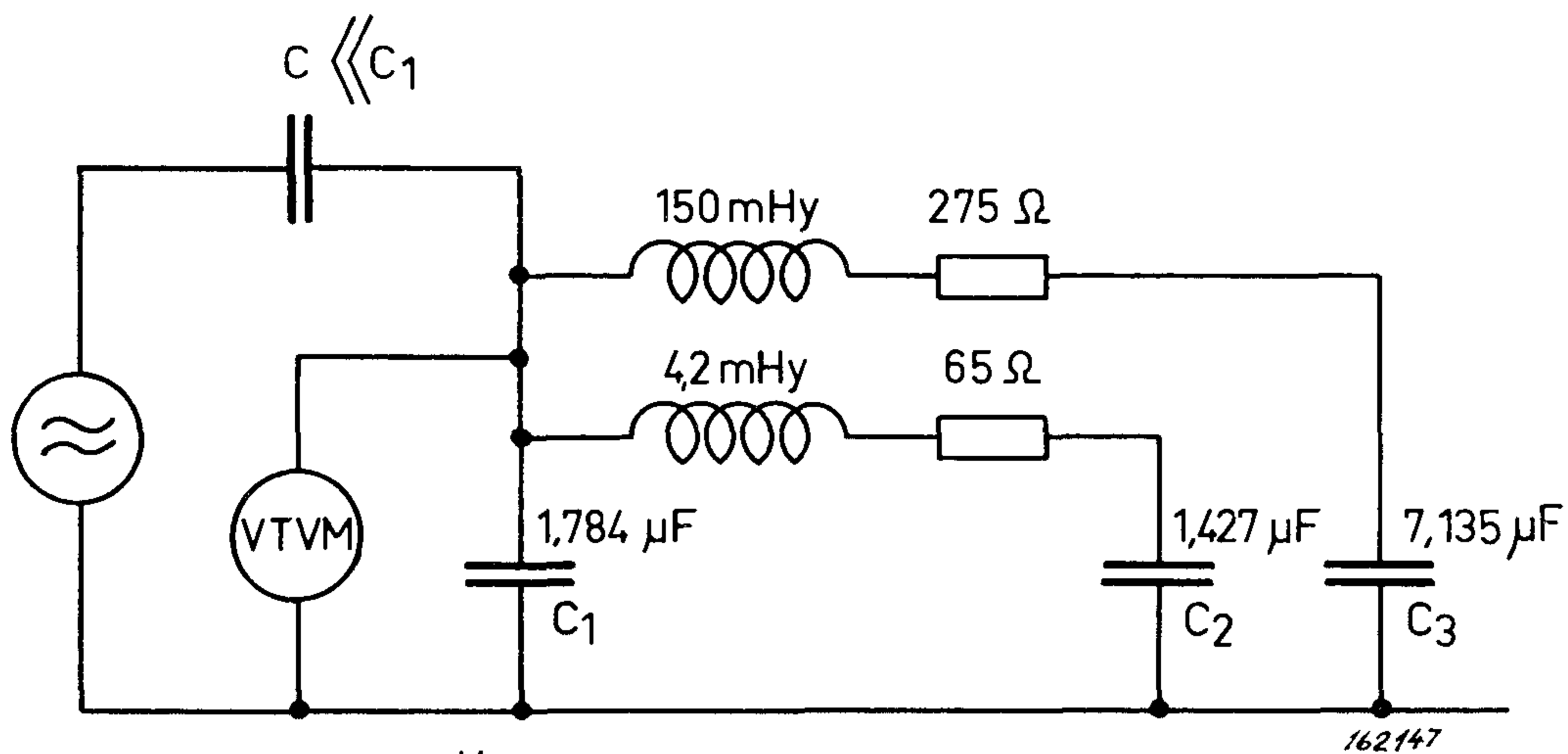

Fig. 27. The B & K Pistonphone Type 4220 used for calibration of the  $\frac{1}{2}$ " microphone in the artificial ear.

The electrical equivalent circuit of the proposed artificial ear may be of interest for impedance measuring purposes. By calculating the volume reactance and experimentally determining the mass reactance and the resistance, an equivalent circuit can be arranged as shown in Fig. 28. The response recorded at the output of the VTVM is shown in Fig. 29. In Fig. 28 the  $10 \text{ cm}^3$  volume is equal to  $C_3$ , the  $2 \text{ cm}^3$  equal to  $C_2$  and the  $2.5 \text{ cm}^3$ , in which the sound pressure level is measured, is equal to  $C_1$ .  $C$  is very small as the equivalent volume of the  $\frac{1}{2}$ " transmitter cartridge used in the standard ear cap is only  $0.007 \text{ cm}^3$ , equal to  $0.005 \mu\text{F}$ . An eventual application of the equivalent electrical circuit would be as an equalizer in the compressor circuit of a B.F.O. like the B & K Type 1014 enabling a linear sound pressure level to be maintained under an ear cap when testing human ears, as proposed in ref. 13. A photograph of the artificial ear is shown in Fig. 30. The ear cap of the receiver under test should rest against the 25 mm edge of the artificial ear. In this way the volume enclosed will depend to some extent on the shape of the ear cap. If the ear cap is made up of soft materials, with rubber pads or similar, a suitable ring should be used as the one shown marked A or B; which one should be specified in each case. If the ear cap is shaped in such a way that a reference seating diameter of 25 mm cannot be obtained, it may rest against the flat part of the artificial ear as shown in Fig. 31d.



$$C_{\text{Acoustical}} = \frac{V}{g c^2} ;$$

$V$  = Volume in  $\text{cm}^3$

$g$  = density of air  $\text{g}/\text{cm}^3$

$c$  = speed of sound in air in  $\text{cm}/\text{sec}$

a)

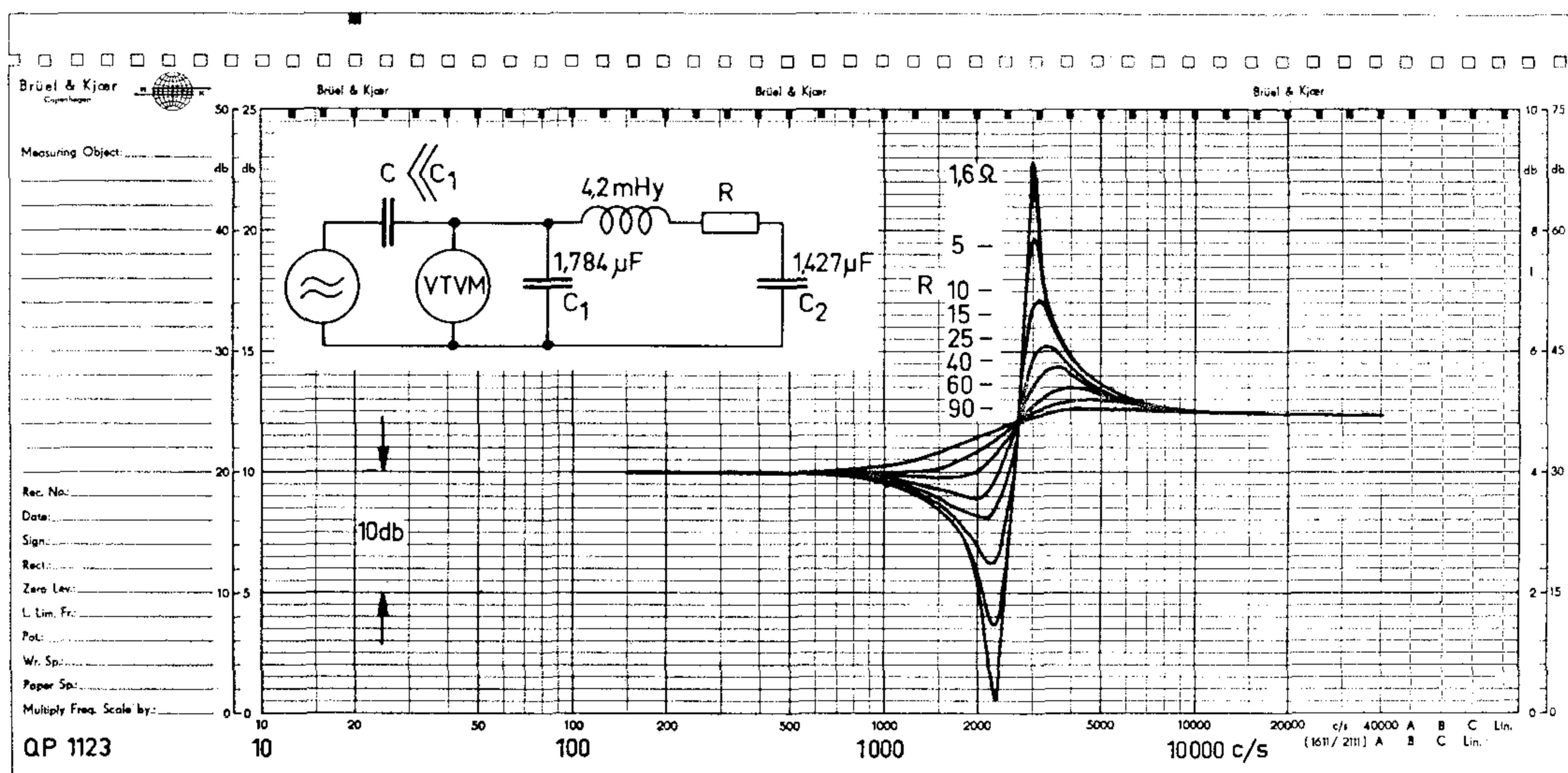

b)

Fig. 28.

- a) Electrical equivalent circuit of the proposed artificial ear. The generator in series with  $C$  represents the high impedance condenser telephone, and the VTVM represents the built-in  $\frac{1}{2}$ " condenser microphone.
- b) The value chosen for the series resistor of  $65 \Omega$  may be determined experimentally by making up to the circuit as shown above, varying  $R$ , and recording the response on a level recorder for different values of  $R$ .

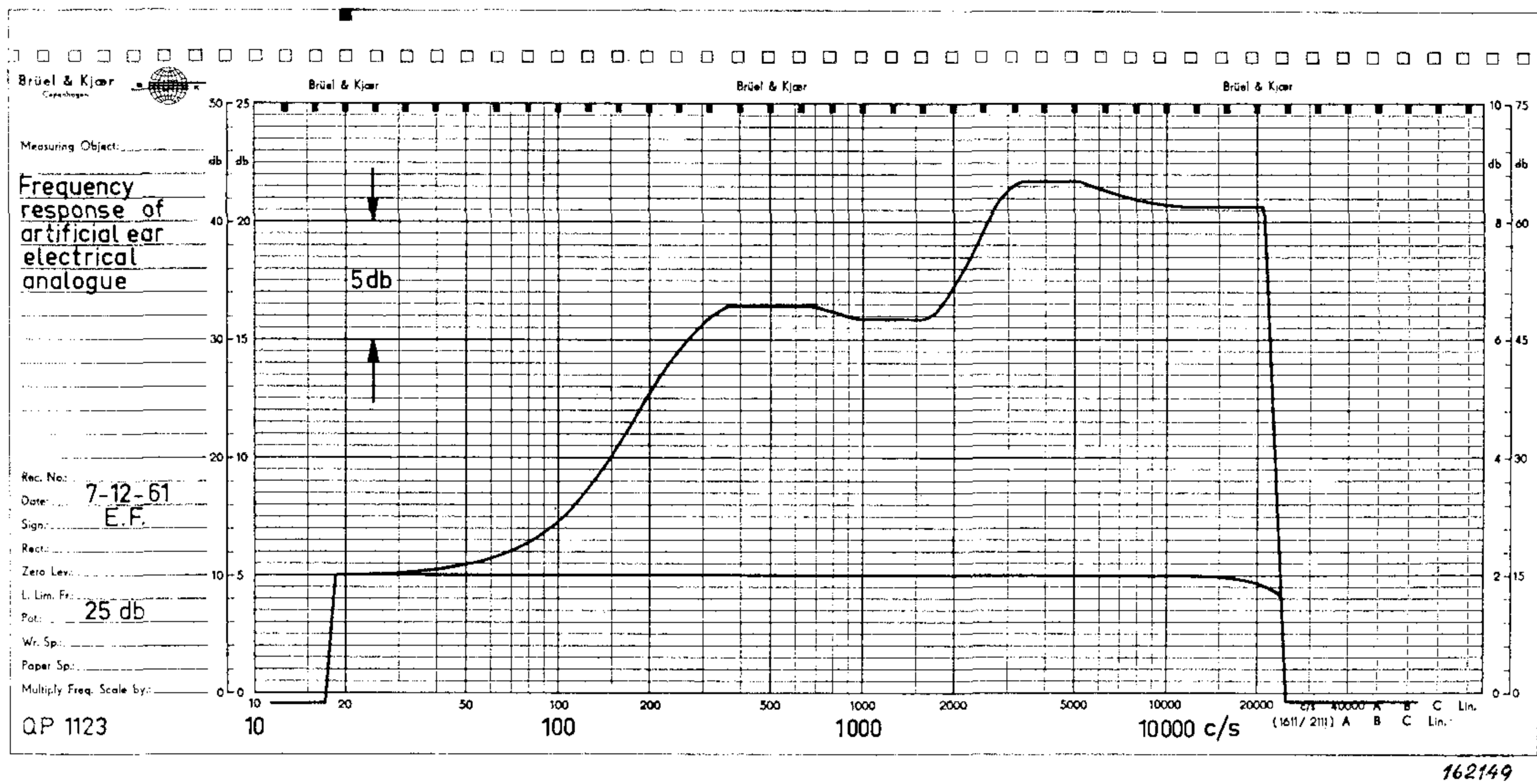

*Fig. 29. The frequency response of the actual electrical equivalent circuit recorded on a level recorder.*

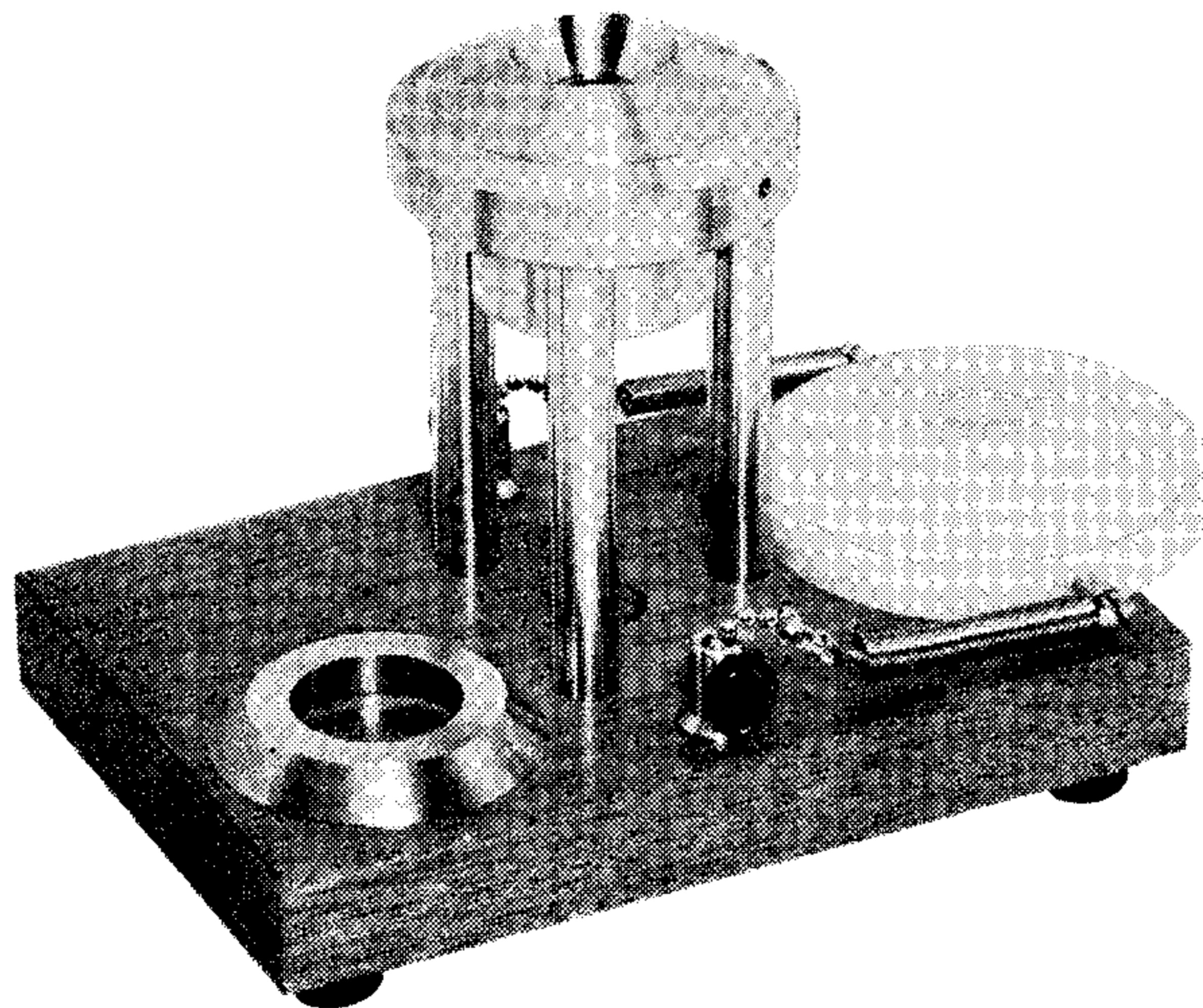

*Fig. 30. Photograph of the complete artificial ear including an extra ring as recommended in the British standard 2042 : 1953.*

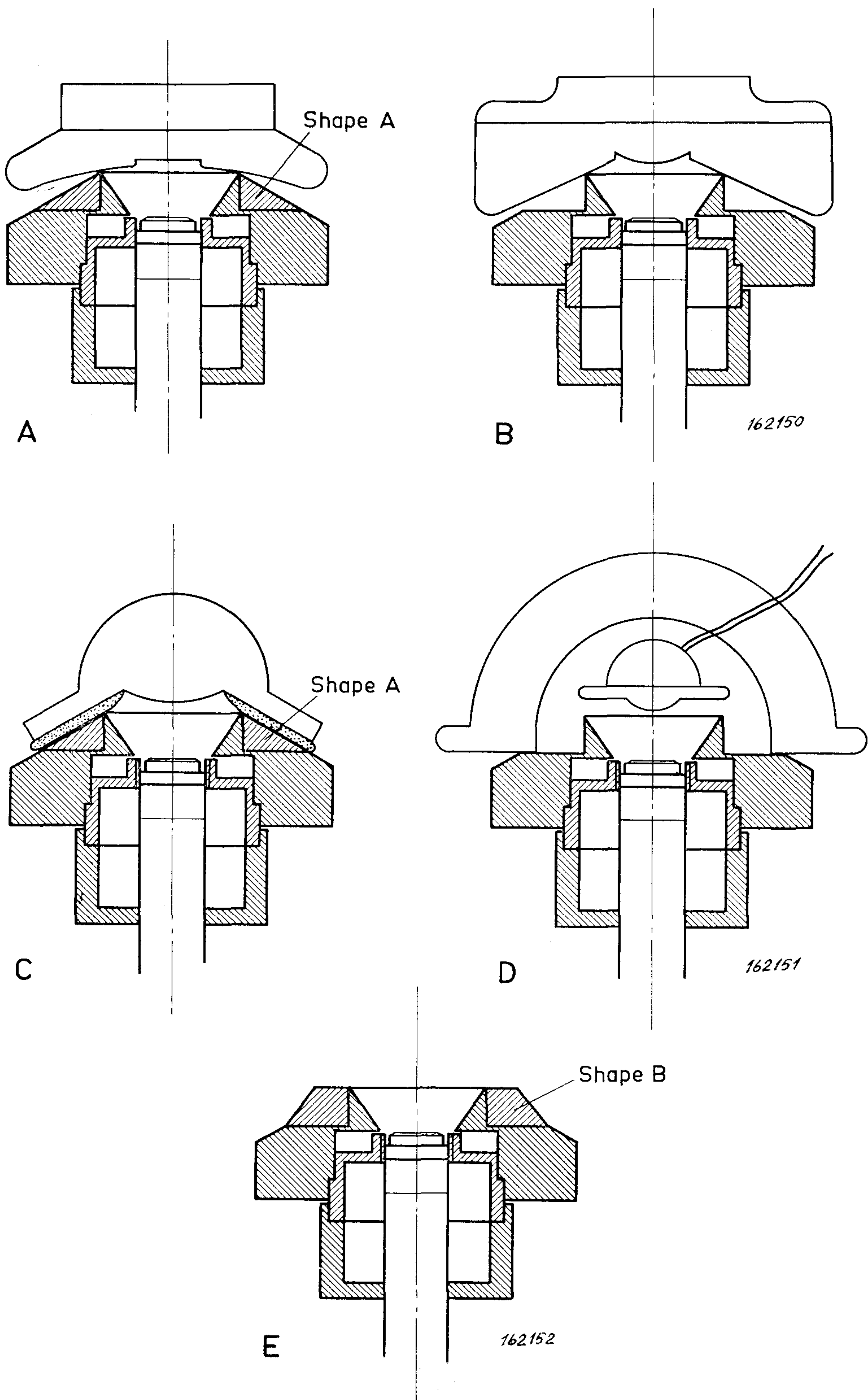

*Fig. 31. Sketches of the different earcaps placed on the artificial ear. It would seem reasonable to recommend the shape A for general use, and whenever other ways of mounting the earcaps are used this should be stated.*

## Appendix

### Electrostatic Standard Earphone without Polarization.

In Fig. 32 at the bottom left an electrical circuit is shown where the microphone cartridge is used without polarization voltage but with a much higher alternating voltage  $e_1$ . In this case a considerably higher sound pressure can be obtained, but with the double frequency of that impressed electrically on the cartridge. It is essential to choose the alternating voltage so high that the D.C. components will be equal to the normal polarization voltage valid for the cartridge in question, in this case 200 V. From the formula (I) page 7 of

T.R. No. 4-1961 comes immediately, the D.C. component  $= \frac{e_1}{\sqrt{2}} = E_0 = 200 \text{ V}$ , i.e. the peak voltage  $e_1$  should be equal to 282 V, or the  $e_{\text{rms}}$  should be equal to 200 V.

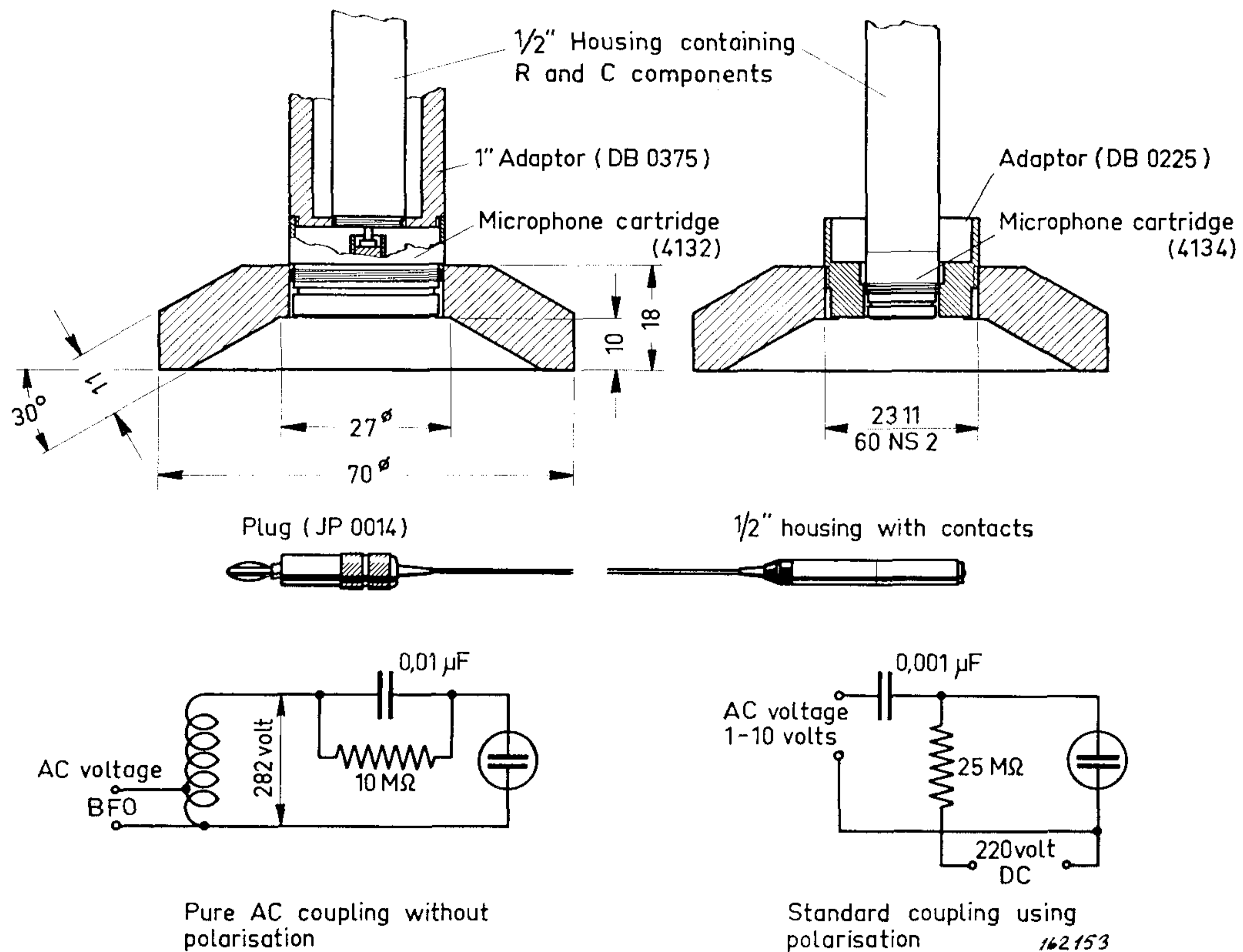

Fig. 32. Circuit and practical arrangement for the use of condenser microphones as transmitters.

If the cartridge can stand a peak value of 282 V, which the small cartridge 4134 can do as it is tested for 300 V, it is possible to obtain a pure sinusoidal sound pressure under the assumption that the impressed voltage from the Beat Frequency Oscillator is without distortion. Normally it is necessary to take the small amount of 2nd and 3rd harmonics into consideration which practically every BFO will produce. The voltage from the oscillator can in general be written:

$$e = e_1 \sin \omega_1 t + e_2 \sin \omega_2 t$$

where  $e_1$  = amplitude of the fundamental electrical voltage with angular frequency  $\omega_1$ .

$e_2$  = amplitude of the distortion component with the angular frequency  $\omega_2$ .

$\omega_2$  = will in practice be either the 2nd or the 3rd harmonic.

The force will be:

$$\text{Force} = \frac{S}{8\pi d^2 300^2} (e_1 \sin \omega_1 t + e_2 \sin \omega_2 t)^2 = \frac{S}{8\pi d^2 300^2} \left[ \frac{e_1^2}{2} - \frac{e_1^2 \cos 2\omega_1 t}{2} + \frac{e_2^2}{2} - \frac{e_2^2 \cos 2\omega_2 t}{2} + e_1 e_2 \cos (\omega_1 - \omega_2)t - e_1 e_2 \cos (\omega_1 + \omega_2)t \right] \text{ dynes} \quad \text{II}$$

It can be seen from the expression that a 2nd or 3rd harmonic in the electrical voltage will produce a double amount of disturbing frequencies in the sound pressure. This is clearly indicated in Table 1, and also the produced side band frequencies are shown.

		BFO electrical	Sound in Earphone
Frequency	2nd harmonic	$f + 2f$	$2f + f + 3f$
Amplitude	2nd harmonic	100 % + 1 %	100 % + 2 % + 2 %
Frequency	3rd harmonic	$f + 3f$	$2f + 2f + 4f$
Amplitude	3rd harmonic	100 % + 1 %	100 % ± 2 % + 2 %

**Table 1**

The Beat Frequency Oscillator 1014 will give maximum 0.5 % 2nd and 3rd harmonics under the most disadvantageous conditions, i.e. that the maximum side band frequencies which can be obtained in the sound pressure using the cartridge without polarization voltage will be 1 %. For the 2nd harmonic the side band can easily be distinguished but for the 3rd harmonic one of the side band frequencies will be just equal to the "fundamental" frequency and give an uncertainty on the amplitude for this frequency of maximum 1 %.

The alternating peak force obtained between the electrode and the diaphragm will be:

$$\text{Force} = \frac{S}{8\pi d^2 300^2} \frac{282^2}{2} = \frac{S}{8\pi d^2 300^2} 39762 \text{ dynes}$$

from which can be seen that the sound pressure is 22 db higher than that obtained with the normal polarization voltage at equal distortion level.

At high amplitudes where the movement of the diaphragm becomes large compared to the distance between diaphragm and electrode, distortion will take place and reduce the maximum output to some degree. In Fig. 33 distortion curves measured for different types of microphone cartridges are shown and compared to the distortion produced in a cartridge due to the ratio between the AC and polarization voltages. It can be seen that the distortion, due to the large vibration amplitudes, depends on the type of

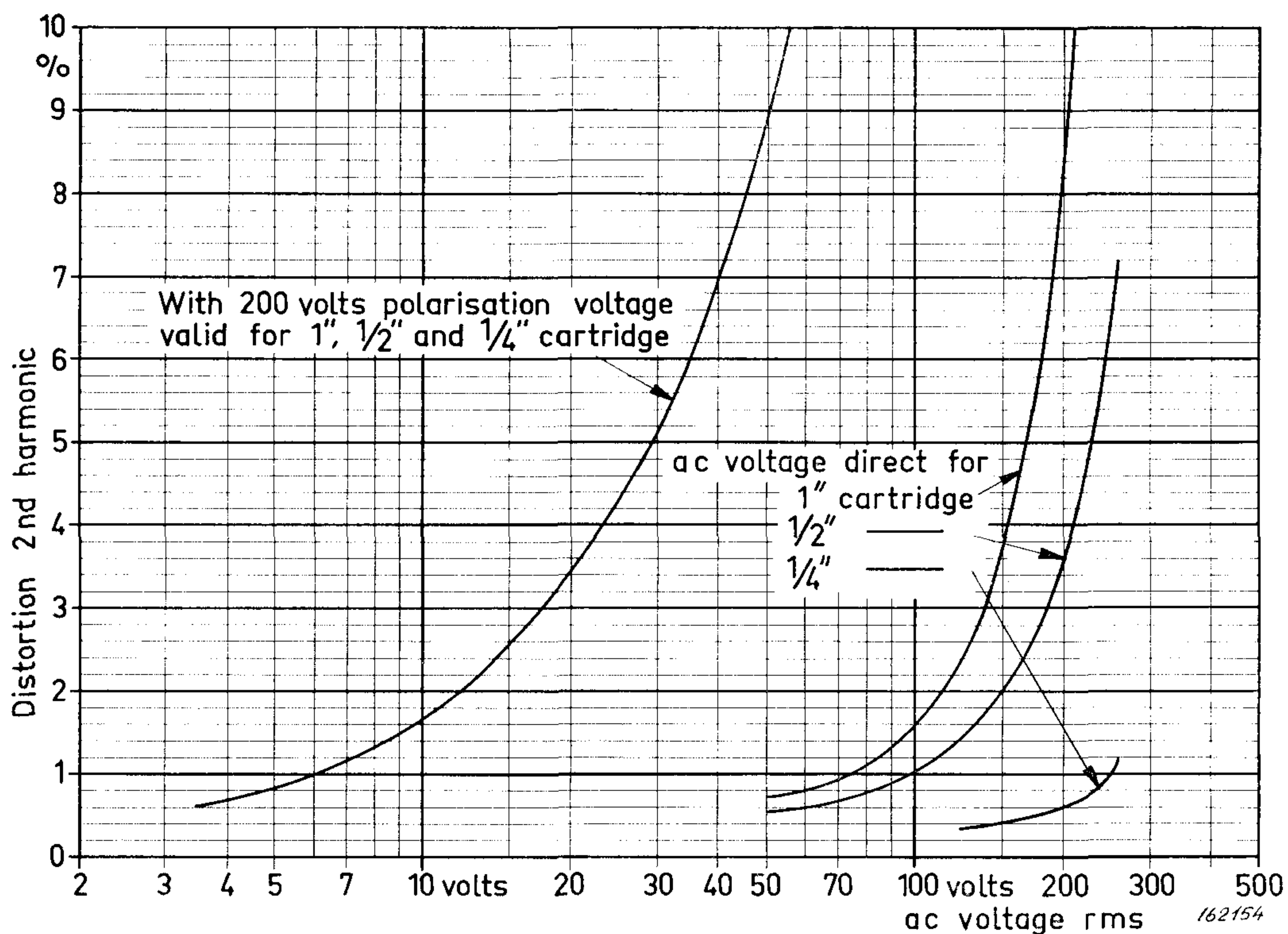

Fig. 33. Second harmonic distortion for 1", 1/2", and 1/4" condenser microphones driven a) in the conventional way, and b) by pure a.c., plotted against r.m.s. driving voltage.

cartridge used. The distortion versus applied voltage is inversely proportional to the sensitivity of the cartridge. If maximum distortion is limited to 1% for a 1/2" cartridge, a maximum AC voltage of 100 Volts RMS can be applied, which results in a force between the electrode and the diaphragm of:

$$\text{Force} = \frac{S}{8\pi d^2 300^2} 1000 \text{ dynes}$$

i.e. about 13 db larger sound pressure than that obtained with the normal polarization voltage. To use only 100 V AC on the cartridge corresponds



to 100 V AC polarization voltage, and for some cartridges the frequency response is here slightly different from "normal" (200 Volts polarization voltage), see Fig. 34.

Another advantage is that owing to the frequency doubling, the "standard" Beat Frequency Oscillator will produce sounds of frequencies up to 40 kc/s. As the Brüel & Kjær Beat Frequency Oscillator 1014 has a complete logarithmic scale, there is no disadvantage combined with the frequency doubling.

In Fig. 35 the sound pressure which this standard earphone will produce in a very small chamber is shown. The curves are taken as the frequency response of the cartridges used as microphones with an electrostatic actuator, but these curves represent exactly the transmitted sound pressure into a capacitive acoustical impedance.

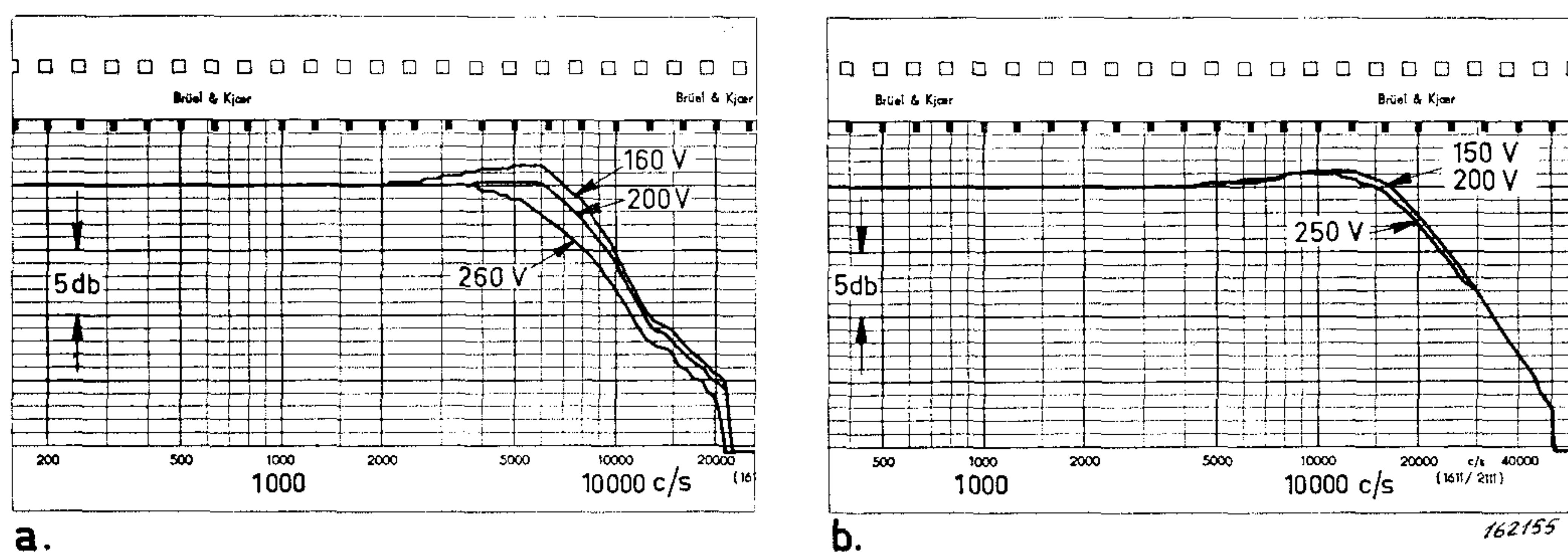

Fig. 34.

- a) Change in frequency response for various polarizing voltages for 1" condenser microphones.  
 b) Same as a) for 1/2" microphones.

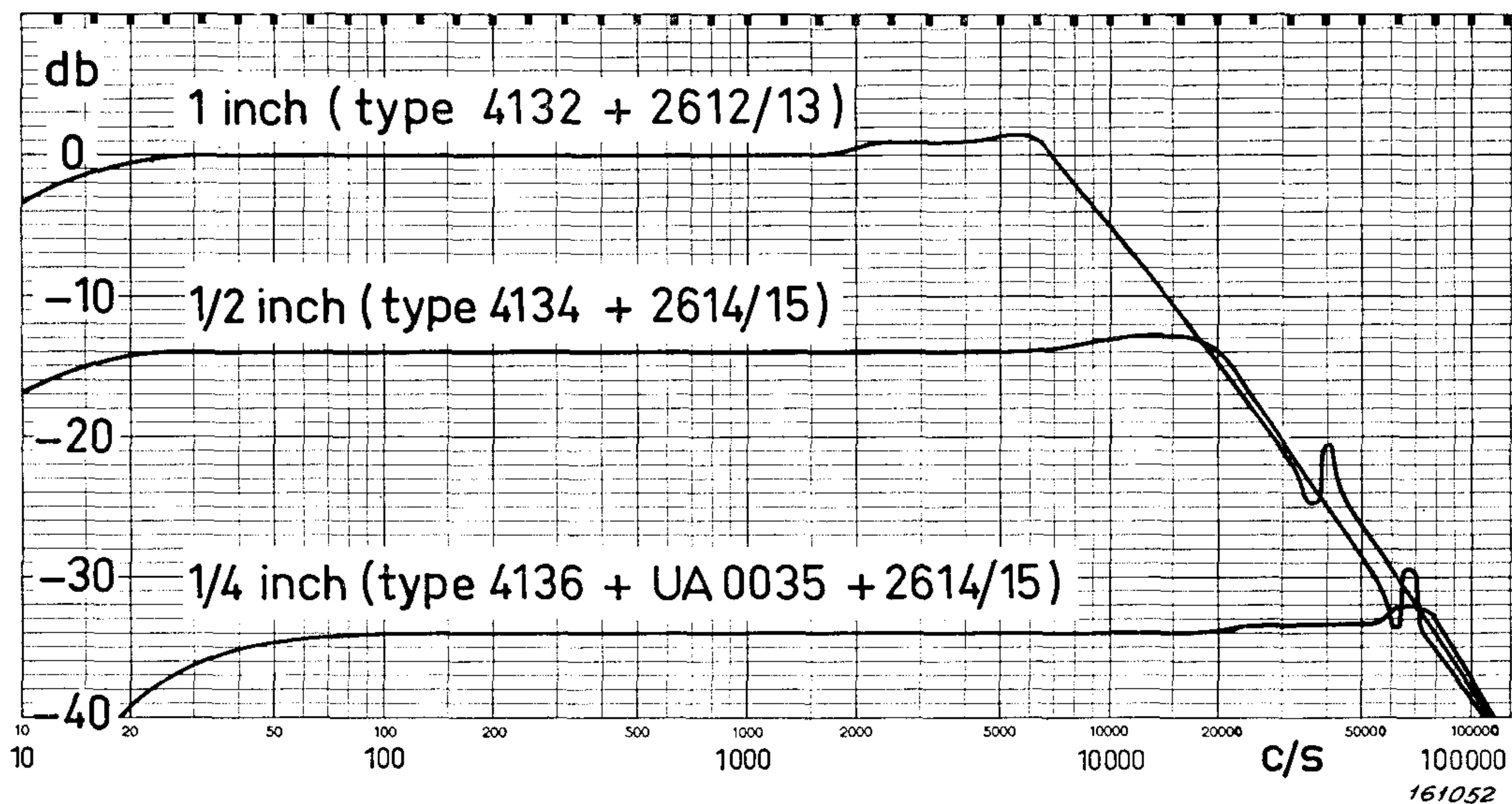

Fig. 35. Pressure frequency response of the condenser microphones used for this work. The 1/2" condenser microphone used as transmitter will give a constant volume displacement within the range 20 c/s — 20 kc/s.

## References:

1. Post office research station. Acoustical Impedance Measurements on Real Ears. Progress Report by F. E. Williams. 1st June 1961.
2. I. Nábělek Proc. of third I.C.A. Congress 1959, page 26 and 28.
3. British Standard 2042: 1953.
4. Bell Telephone MFG Co. Physical Laboratory Antwerp Report 2 T N. 7068V.
5. Acoustical Impedance of the Human Ear as Seen from a Telephone Receiver Cap. Case 20727-3 by W. F. Clemency.
6. Mahlon D. Burkhard and E. L. R. Corliss. The response of earphone in ears and couplers. JASA, Vol. 26, page 680.
7. Effects de la valeur de la force d'application sur la response de econteurs d'audiometrie. Par I. Barducci presented for the working group 29/11 of IEC in June, 1961.
8. I. Barducci et F. Bianchi. Contribution aux methodes d'Etalonnage de Econteurs de Haite Quàlite. Proc. of the third I.C.A. Congress 1959.
9. S. C. Dalsgaard. Some Calculations and Measurements of the Sound Distribution in 2 cm<sup>3</sup> Coupler Cavities. Proc. of the third I.C.A. Congress, 1959.
10. See f. ex. Systeme de Contrôle Objectif de l'Efficacité des Appareils d'Abonne's par P. Chavasse Centre National d'Etudes des Telecommunications. Paris, Proc, of third I.C.A. Congress, 1959, page 618.
11. L. Beranek. Acoustic Measurement, page 740, fig. 16—24.
12. P. V. Brüel and G. Rasmussen, Brüel & Kjær Technical Review No. 2, April 1959.
13. R. Feldtkeller and E. Zwicker. Das Ohr als Nachrichtenempfänger, p. 7.

## **The Fourth International Congress on Acoustics.**

The Fourth International Congress on Acoustics will be held in Copenhagen from August 21th — 28th, 1962. It is this time organized by the Acoustical Society of Denmark, and the address of the secretariat is:

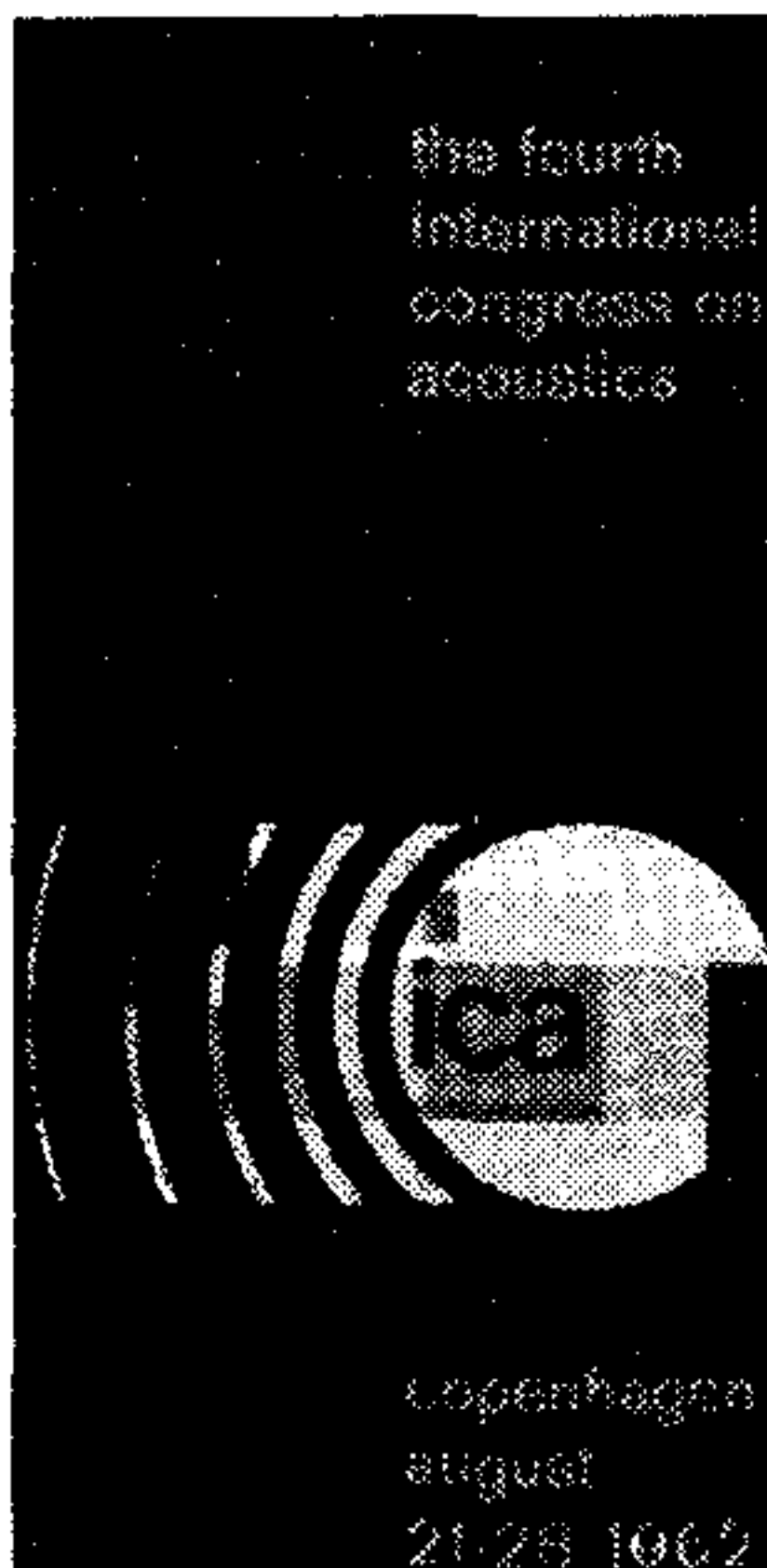

**Fourth International Congress on Acoustics**

**Oestervoldgade 10**

**Copenhagen K**

**Denmark**

All technical sessions will be held at the Technical University of Denmark (Polyteknisk Lærestalt, Danmarks tekniske Højskole), Oestervoldgade 10, and the major topics of the congress are:

**Bioacoustics**

**Physical Acoustics**

**Noise Control**

During the congress, convenient means of transportation from the congress building to the Brüel & Kjær factory in Nærum will be arranged by Brüel & Kjær.

Parallel with the international exhibition of acoustical measuring instruments, other acoustical equipment, and acoustical materials in the congress building, a special exhibition of acoustical instruments produced by Brüel & Kjær will be organized at the factory in Nærum.

Brüel & Kjær invite engineers and scientists from the congress to visit their facilities, and to discuss specific problems with measurement specialists in the laboratories in Nærum.

## News from the Factory.

### **Tapping Machine Type 3204.**

The Tapping Machine Type 3204 meets the requirement of I.S.O. Recommendation R 140 for field and laboratory measurement of impact sound transmission in buildings.

It is powered by a self-starting synchronous motor, there being provision to operate the motor on either 50 c/s or 60 c/s supplies, 100, 115, 127, 150, 220, or 240 V. The overall gear ratio of the mechanical drive to the tappet mechanism can be adjusted so that, for either mains frequency, the hammers make exactly ten impacts per second.

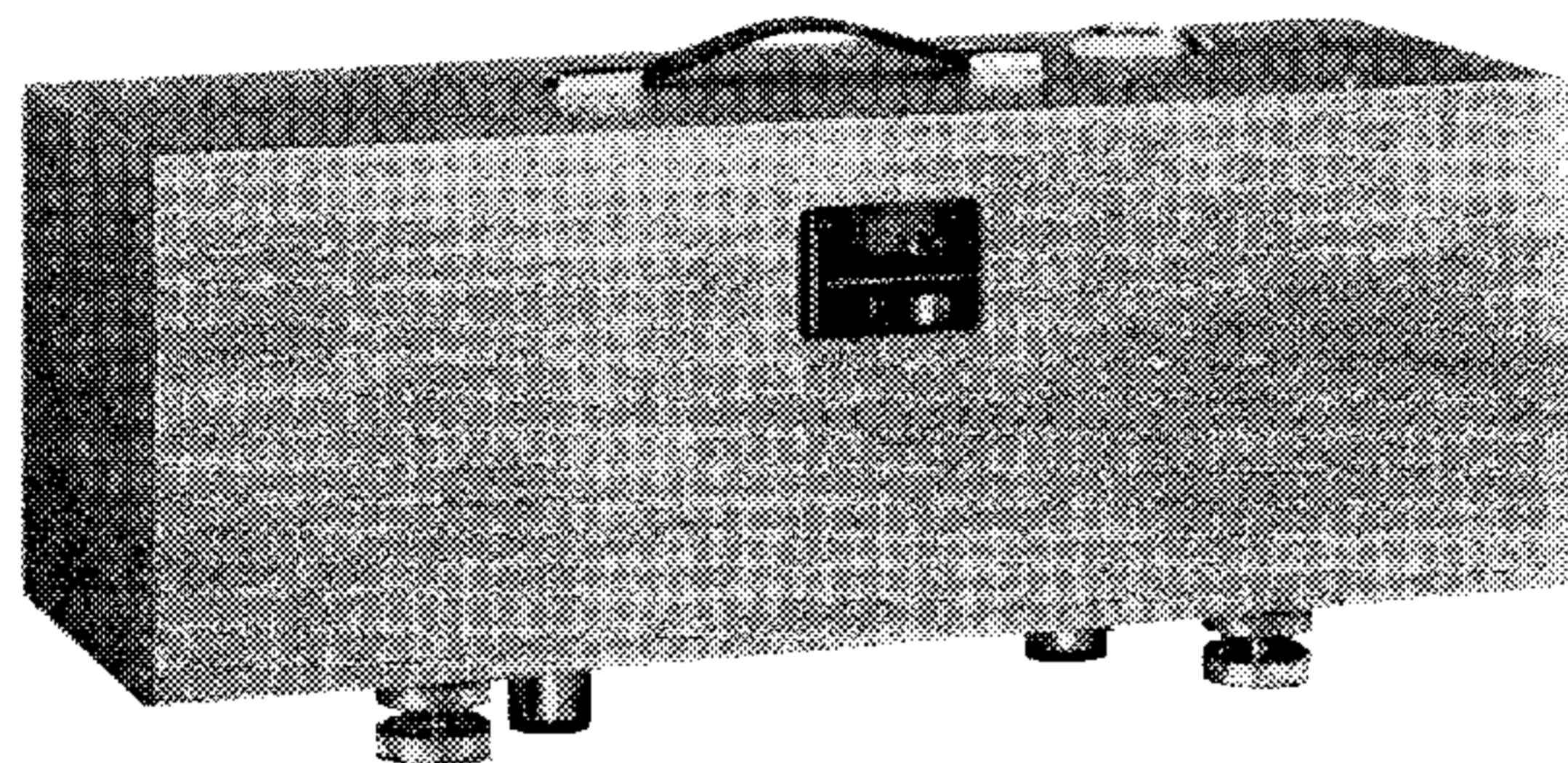

Two types of hammer heads are supplied, — stainless steel and rubber, the falling mass being 500 grammes in either case.

The apparatus is set up to tap the floor of a room and then, by the I.S.O. definition, the impact sound transmission properties are characterised by the spectrum of the noise produced in another room. This spectrum should be analysed in  $\frac{1}{1}$  octave bands (alternatively  $\frac{1}{2}$  or  $\frac{1}{3}$  octave bands).

### **Accelerometer Preamplifier Type 2620.**

This instrument, which is basically a two-channel preamplifier, has been designed especially as an interconnecting *link between one or two accelerometers and the Automatic Vibration Exciter Control Type 1018.*

The purpose of the instrument is to obtain a first stage of amplification near the accelerometer, thereby reducing the influence from the long cables often necessary between the accelerometer and the exciter control. It also allows simple and convenient sensitivity matching to a variety of accelerometers.

The input impedance of Type 2620 is approx.  $100\text{ M}\Omega$  paralleled by 10 pF, and the gain is variable between 1 and 0.1 corresponding to an accelerometer sensitivity range of 10—100 mV/G. *The calibrated dial of Type 2620 should be set to the actual sensitivity of the Accelerometer, as given by the manufacturer. The output from the Preamplifier will then correspond to the output of an accelerometer with a sensitivity of exactly 10 mV/G.* The output impedance of “Main Output” is approximately  $1000\ \Omega$ , and of “Monitor Output” max.  $10\text{ k}\Omega$ . The frequency response is flat to within  $\pm 0.2$  db between the lower limiting frequency and 5 kc/s, it is  $0.5 \pm 0.5$  db down at 10 kc/s and more than 40 db lower at 18 kc/s.

To cut off low frequency noise from the cathode follower and wind noise from the accelerometer an adjustable high-pass filter has been inserted with cut-off frequencies of 5, 10, and 50 c/s.

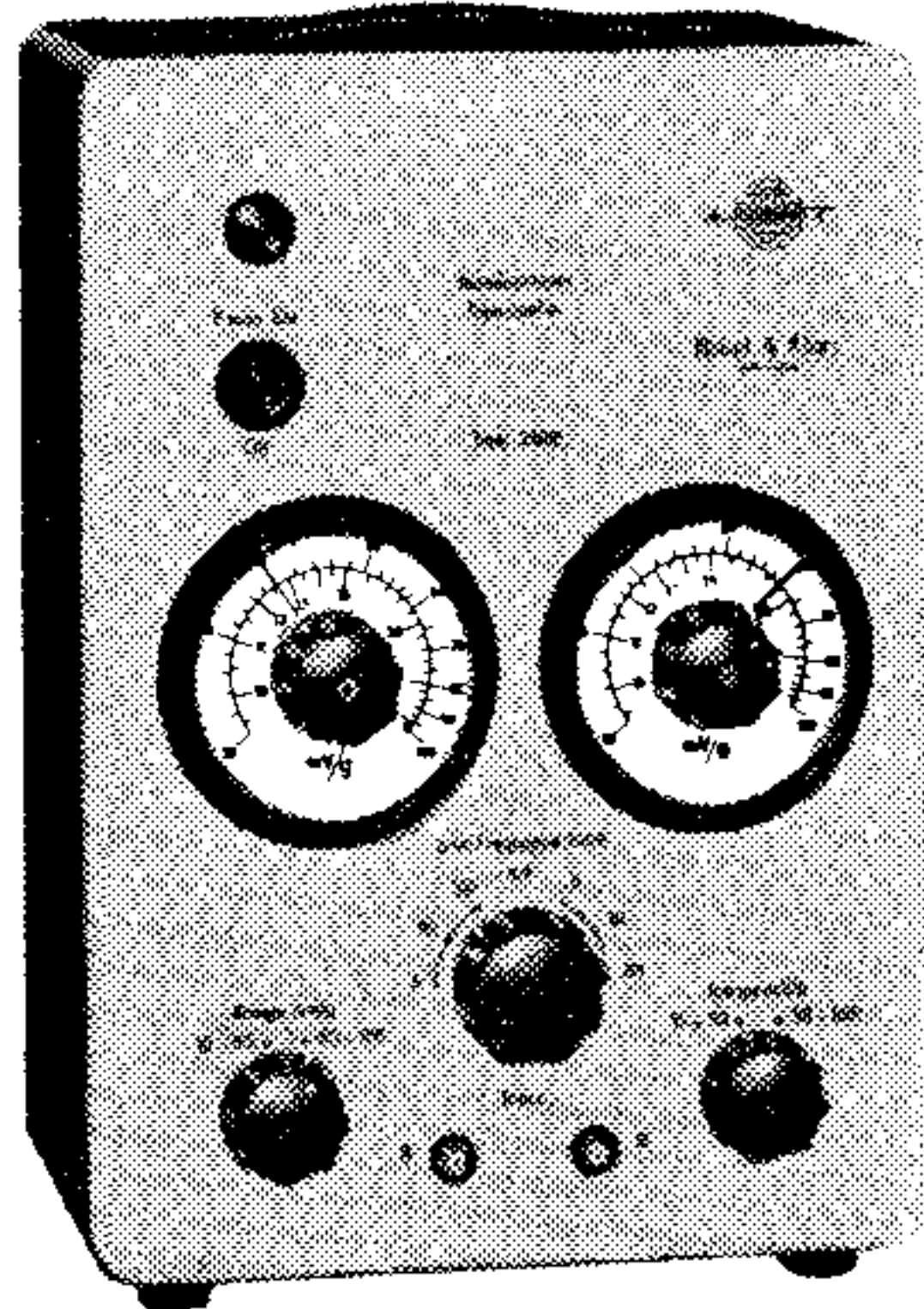

The two channels are marked "A" and "B" respectively. With the switch "Low Frequency Limit" in position "A", channel "A" is connected to the "Main Output" terminal and channel "B" to the "Monitor Output" terminal (level: 6 db lower and without high-pass filter). With the switch in position "B" the two output terminals are interchanged.

The ground is isolated from the steel case to avoid group loops. On the top of the case is mounted a plastic covered carrying handle.

### **Octave Filter Set Type 1613.**

A new Octave Filter Set containing 11 octave filters with center frequencies ranging from 31.5 c/s to 31.5 kc/s is now in production. The unit is mechanically designed to be fitted onto the case of the Sound Level Meter, whereby the total length of the 2203 + 1613 is 47 cm (18½").

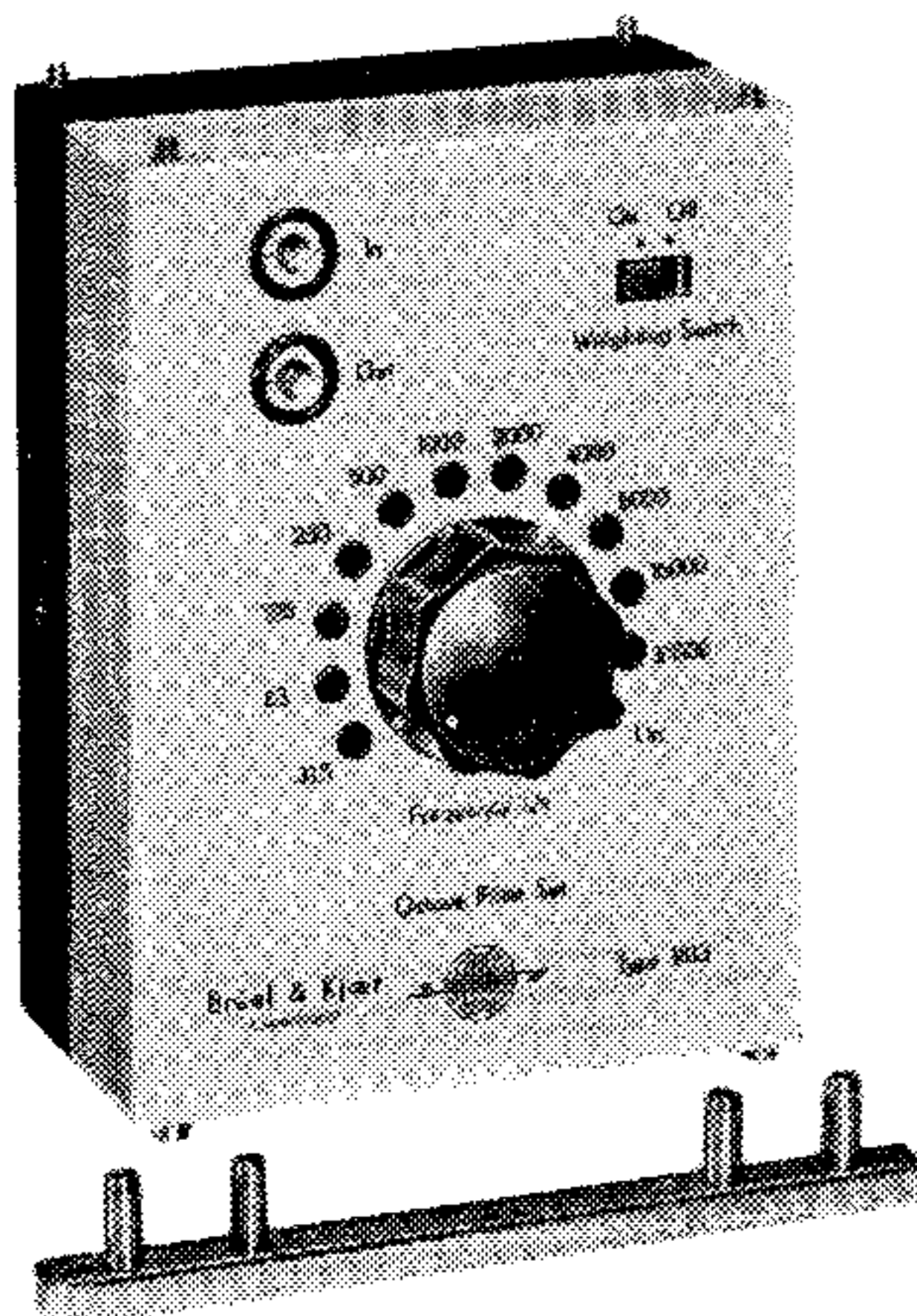

However, the Filter set can also be used separately and should be fed from a source impedance of less than 25  $\Omega$ . The loading of the filter should be 146 k $\Omega$  (exactly) paralleled by 50 pF. These conditions are fulfilled both

when the Filter Set is used with the Precision Sound Level Meter Type 2203 and when it is used with the Microphone Amplifier Type 2604.

A screwdriver operated potentiometer with an adjustable dynamic range of more than 50 db is connected at the output of each octave filter. In this way any desired pre-set weighting can be made. The potentiometers can be switched in or out of circuit by means of a switch marked "Weighting On/Off".

The ripple in the pass-band of the filter is less than  $\pm 0.5$  db. The attenuation at the band limits is 3 db. Attenuation 1 octave away from center frequency approximately 25 db. Attenuation 2 octaves away from center frequency approximately 50 db. The maximum slope of the attenuation characteristic is 50 db/octave, and the end slope is 18 db/octave.

### **The Noise Limit Indicator Type 2211**

is designed to provide a high-speed accurate assessment of the quality of production line outputs as regards noise and vibration of the product.

This is achieved by a rapid measurement of every unit leaving the production line and by automatically comparing the results with a pre-set "standard" for this type of unit. The instrument measures noise and vibration levels in several (up to 12) frequency bands simultaneously.

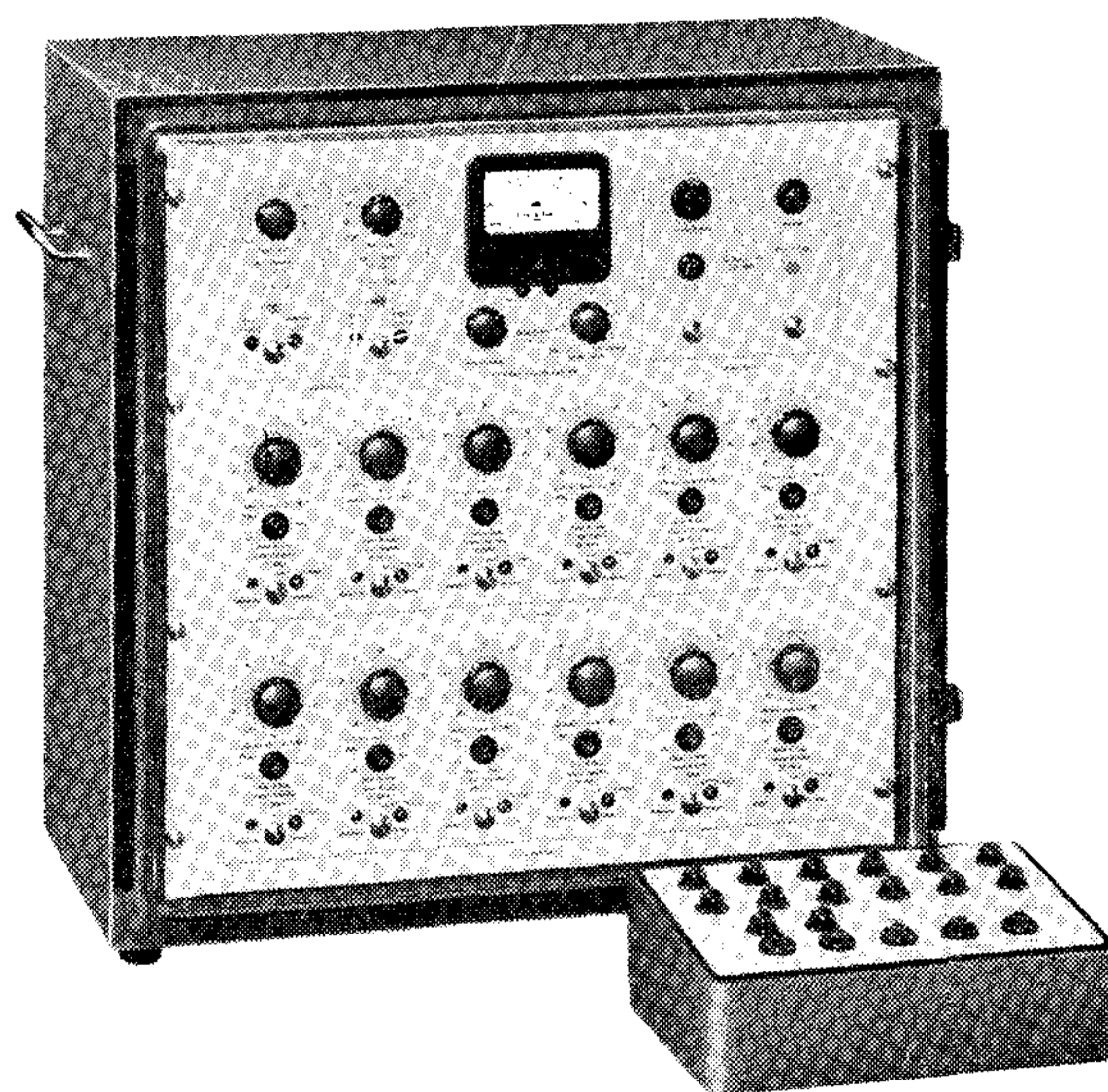

It has been designed to offer the utmost simplicity in operation after setting up, and an untrained worker can easily interpret the indicating panel and thereby even the acceptance or rejection of the unit manufactured. Rejections are indicated by means of red indicating lamps, thus eliminating the possibility of confusion or errors from meter readings. For normal "go — no go" testing the operator's job is reduced to the following:

- a) Press the "measure" button on the control panel
- b) Note if any of the lamps light up
- c) Label the tested unit, to indicate whether it has passed the test or not.

Rejects should be labelled with the number of the red indicating lamp, thereby informing the repair shop about the frequency band in which the noise limit has been exceeded. In many cases this also identifies the error to be corrected. The total operation time for the assessment by this apparatus is extremely short. When conveniently set up, the testing for excess noise and vibration can normally be carried out in less than 10 seconds.

By means of a "Sensitivity Increase" circuit it is possible to divide the accepted units in two classes (by using both input channels even in four classes). That is, when it is checked that the unit under test passes the standard requirements, a quick extra check (1 second) classifies the unit as "standard" or "extra-fine" with respect to noise and vibration.

### **Mobile Laboratory Tables Type 3113.**

To meet the increasing demand for mobile laboratories B & K have now developed a special set of tables and installation equipment which, in addition to a set of B & K instruments, will form a complete mobile laboratory. Based upon the experience obtained from the outfit used by the B & K travelling engineers the equipment includes:

Tables with means for fixing to automobile deck and folding wheels for short distance transportation.

Drawers with locks.

Complete power cable installation so that only one mains connection is needed.

Complete fixing equipment for table top mounting of instruments, or total mounting and fixing to automobile carried out at our factory to order.

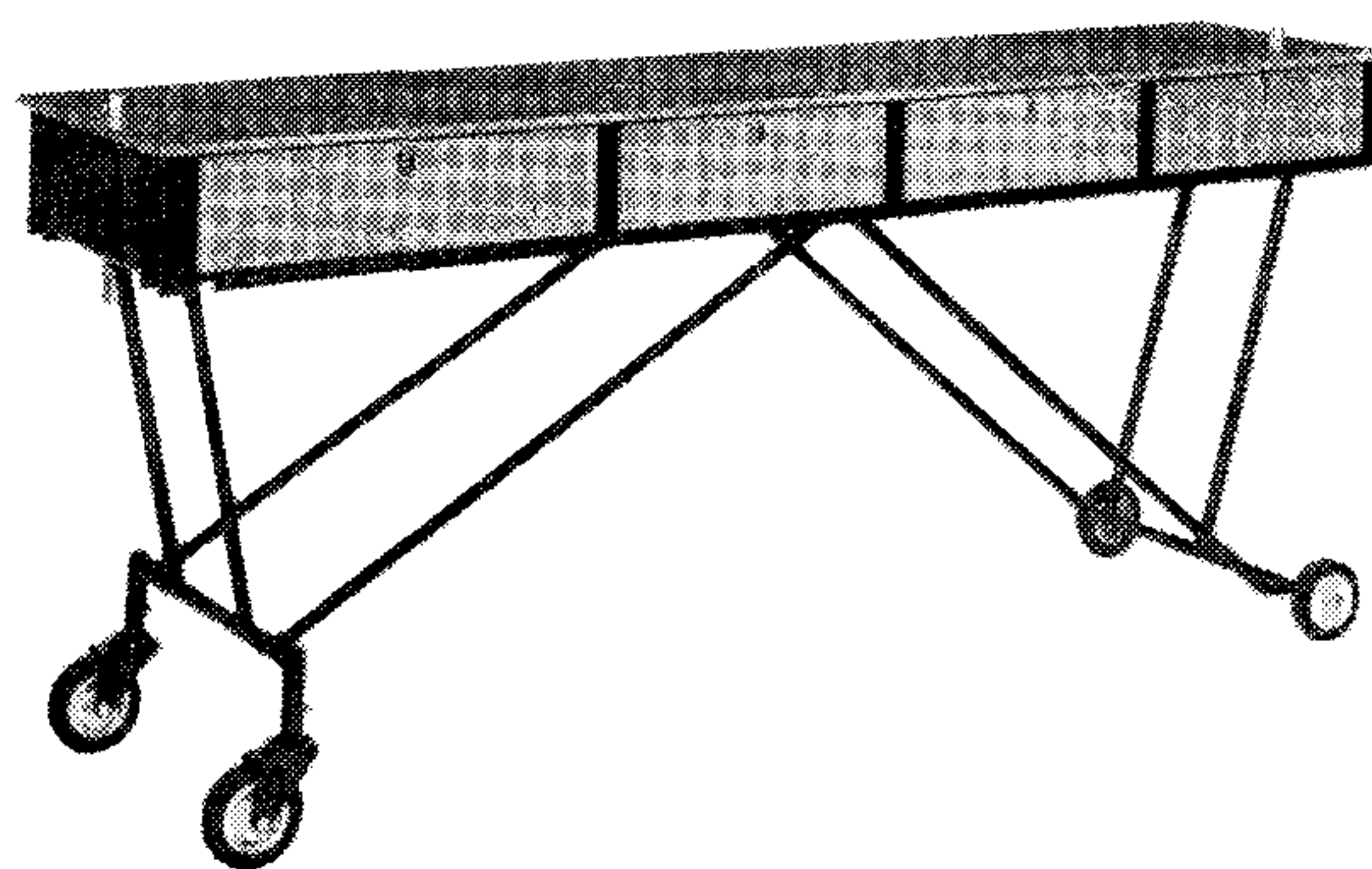

A suitable automobile may be supplied by a Copenhagen dealer on special order and at current price (f.o.b. Copenhagen). We would recommend Ford or Chevrolet station wagon types for this purpose.

By means of this equipment a full set of integrated measuring instruments can be installed in a normal station wagon of suitable size, thus converting it into a mobile laboratory.

The entire set-up of instruments, tables with drawers and power installation can be removed from the automobile in less than two minutes by only one

person, and may then be moved by means of the retractable wheels, still forming a fixed set-up for immediate use.

Some of the measuring arrangements that may be installed in an automobile by means of two tables are for instance:

1. Complete measuring set-up for the measurement of acoustical properties of buildings.
2. Complete measuring arrangement including selector and distribution panels for strain gage measurements.
3. A combined measuring set-up for general service purpose, or special measuring arrangements according to customer's specification.

### **Magnetic Transducers MM 0002.**

The Magnetic Transducers MM 0002 are especially designed to be used in combination with B & K equipment. The connection cables which are teflon-isolated can stand temperatures of up to  $+250^{\circ}\text{C}$  ( $+480^{\circ}\text{F}$ ). Ten high- $\mu$  discs YO 0010 are supplied with each transducer. The discs are intended for use in conjunction with the measurement of internal damping and dynamic elasticity (complex modulus) of amagnetic, solid materials. (Two MM 0002 Transducers are included in the Complex Modulus Apparatus Type 3930). The

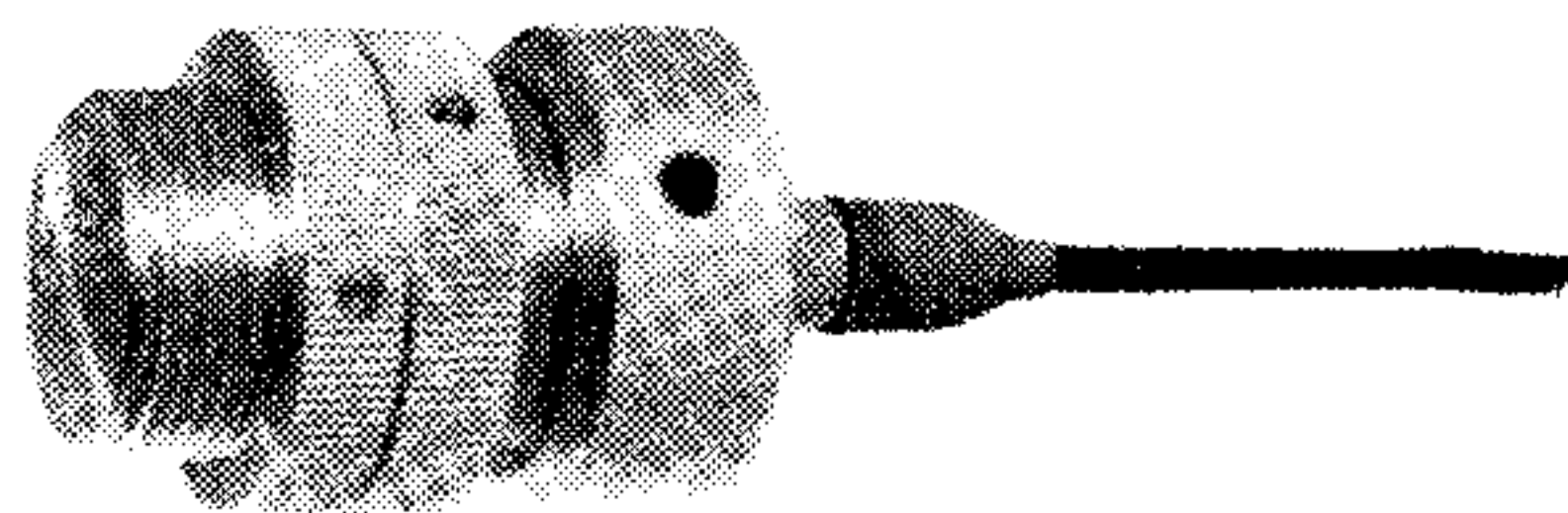

open circuit sensitivity of the transducer is about  $1.5 \text{ mV/cm sec}^{-1}$  when it is placed at a static distance 2 mm from the high- $\mu$  disc. In front of a large iron plate the sensitivity is around 8 db higher (2.5 times higher) than in front of the high- $\mu$  disc. It remains fairly constant throughout the audio-frequency range (varies less than  $\pm 1 \text{ db}$  up to 2000 c/s with high- $\mu$  Disc).

The impedance is  $1800 \Omega$  in series with 400 mH with open magnetic circuit and the maximum input voltage is around 100 V (maximum continuous power dissipation is 5 W at  $20^{\circ}\text{C}$ ).



# Brüel & Kjær

ADR.: BRÜEL & KJÆR  
NÆRUM - DENMARK



TELEX 5316

TELEPHONE: 800500  
⚡ BRUKJA, Copenhagen

Printed in Copenhagen, Denmark